

**HAFCO METALMASTER**

# TURRET MILL OPERATION MANUAL

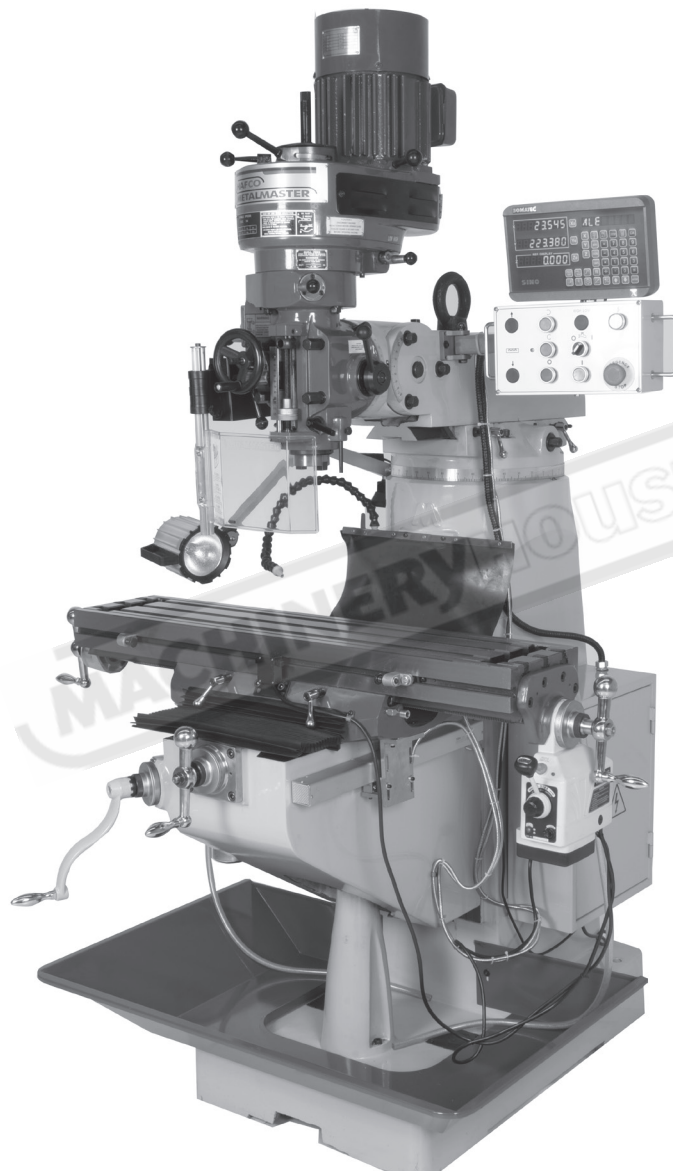

**Models.**  
**BM-23A, BM-53VE, BM-63VE**

*Edition No* : TM-001

*Date of Issue* : 6/2017



# OPERATION MANUAL

## MACHINE DETAILS

<b>MACHINE</b>	TURRET MILL
<b>MODEL NO.</b>	
<b>SERIAL NO.</b>	
<b>DATE OF MANF.</b>	

Distributed by



[www.machineryhouse.com.au](http://www.machineryhouse.com.au)

[www.machineryhouse.co.nz](http://www.machineryhouse.co.nz)

**NOTE:**

This manual is only for your reference. Owing to the continuous improvement of the machine, changes may be made at any time without obligation or notice. Please ensure the local voltage is the same as listed on the specification plate before operating this electric machine.



**NOTE:**

In order to see the type and model of the machine, please see the specification plate. Usually found on the back of the machine. See example (Fig.1)

**HAFCO**  
PRODUCT SPECIFICATION

MODEL:

CAPACITY:

SER. NO:

MFG DATE:

WEIGHT:

VOLTS:

MOTOR Kw:

[www.machineryhouse.com.au](http://www.machineryhouse.com.au)  
Made in China

Fig.1



## OPERATION MANUAL

### CONTENTS

#### INTRODUCTION

Specifications.....	4
Front View Identification.....	5
<b>BM-23A</b> Belt Driven Head Identification.....	6
<b>BM-23A</b> Controls And Components.....	7
<b>BM-53VE, 63VE</b> Variable Head Identification.....	8
<b>BM-53VE, 63VE</b> Controls And Components.....	9
Table Identification.....	10
Safety Operating Procedures.....	11
Safety Requirements.....	12

#### SET-UP AND INSTALLATION

Preparing the Milling Machine for Service.....	13
Leveling the Machine.....	13
Removal Of Mill Head Block.....	14
Electrical Connection.....	14
Electrical Requirement.....	14
Extension Cords.....	14

#### OPERATING INSTRUCTIONS

Operating Controls.....	14
Motor Switch.....	14
Setting BM-23A Spindle Speed.....	15
Setting Variable Head Speeds.....	16
Variable Speed Control.....	17
High-Neutral-Low Shift Lever.....	17
Spindle Brake.....	17
Quill Feed Level.....	18
Feed Rate Lever.....	18
Feed Clutch Lever.....	18
Feed Direction Control.....	18
Coarse Feed Handle.....	19
Quill Lock Lever.....	19
Micrometer Adjusting Nut.....	19
Fine Feed Wheel.....	19
Depth Scale and Stop.....	19
Spindle Downfeed Operation.....	20
Loading and Unloading Tooling.....	21

#### ADJUSTMENTS

Mill Head – Fore/Aft Adjustment.....	22
Mill Head – Left/Right Adjustment.....	22
Returning to Upright Position.....	23
Positioning the Ram.....	24

#### MAINTENANCE

Lubrication.....	25
Gib Adjustment.....	26
Troubleshooting.....	27

#### PARTS

How to Order Spare Parts.....	29
BM-23A Belt Drive Head Parts.....	30
BM-23A Parts List for Head Assembly.....	31
Spindle Assembly.....	33
Parts List for Spindle Assembly.....	34
BM-53VE Head Assembly Parts.....	32
BM-53VE Part List for Head Assembly.....	37
BM-53VE Head Assembly Parts.....	38
Base Assembly.....	41
Parts List for Base Assembly.....	42
Lead Screw Assembly Parts.....	44
Parts List for Lead Screw Assembly.....	45
One-Shot Lubrication System.....	46
Parts List for One-Shot Lubrication System.....	46

#### APPENDIX

Risk Assessment.....	47
----------------------	----



## OPERATION MANUAL

### INTRODUCTION

This manual covers the safe operation and maintenance procedures for the Hafco/Metalmaster Turret Mills with model numbers listed below in the specifications. These machines have been designed and constructed to provide years of trouble free operation if used in accordance with the instructions set forth in this manual.

**NOTE: Some sections may apply only to certain models. Please be sure you know your model.**

### SPECIFICATIONS

Model Number:	BM-23A	BM-53VE	BM-63VE
Digital Readout	3-Axis Counter X, Y Scales	3-Axis	3-Axis
Table Size (mm)	1066 x 230	1370 x 254	1370 x 254
Spindle Taper	NT30	NT-40	NT-40
Longitudinal Travel X-Axis (mm)	585	910	890
Cross Travel Y-Axis (mm)	295	400	400
Vertical Travel Z-Axis (mm)	400	385	400
Type of Slides	Dovetail (X, Y, Z)	Dovetail (X) Square (Y & Z)	Dovetail (X) Square (Y & Z)
Longitudinal and Cross Travel Type	Lead Screws	Lead Screws	Ball Screws
Ram Travel (mm)	420	555	550
Quill Diameter (mm)	86	86	105
Quill Travel (mm)	127	127	127
Spindle to Table Max. (mm)	480	385	450
Throat Depth Max. (mm)	545	635	740
Tilting Head (Left to Right)	±90 °	±90 °	±90 °
Tilting Head (Forward & Back)	±45 °	±45 °	±45 °
Power Feed - Quill	0.04, 0.08, 0.15mm/rev	0.04, 0.08, 0.15mm/rev	0.04, 0.08, 0.15mm/rev
Power Feed - Longitudinal (X-Axis)	20-2000 mm/min	20 - 2000 mm/min	20 - 2000 mm/min
Power Feed - Cross (Y-Axis)	Optional	20 - 2000 mm/min	20 - 2000 mm/min
Power Feed - Vertical (Z-Axis)	Optional	Rapid	Rapid
Lubrication System	One Shot	One Shot	One Shot
Table T-Slot Size (mm)	16	16	16
Work Table Load Capacity (Kgs)	250	350	400
Spindle Speeds Vertical	8 Steps (65-2330) rpm	Variable (50 - 3550) rpm	Variable (50 - 3550) rpm
Motor Power - Vertical	2.2kW/3HP 1Ph	3.75kW/5hp	3.75kW/5hp
Motor Voltage	240V-15amp	415V-20amp	415V-20amp
Overall Dimensions (mm./W x D x H)	1500 x 1700 x 2200	1800 x 2430 x 2200	1800 x 2430 x 2200
Net Weight (kgs.)	1100	1365	1375

The above specifications were current at the time this manual was published, but because of our policy of continuous improvement, we reserve the right to change specifications at any time and without prior notice, without incurring obligations

**FRONT VIEW IDENTIFICATION**

Become familiar with the names and locations of the controls and features shown below to better understand the instructions in this manual.

**BM-23A  
DISPLAYED**

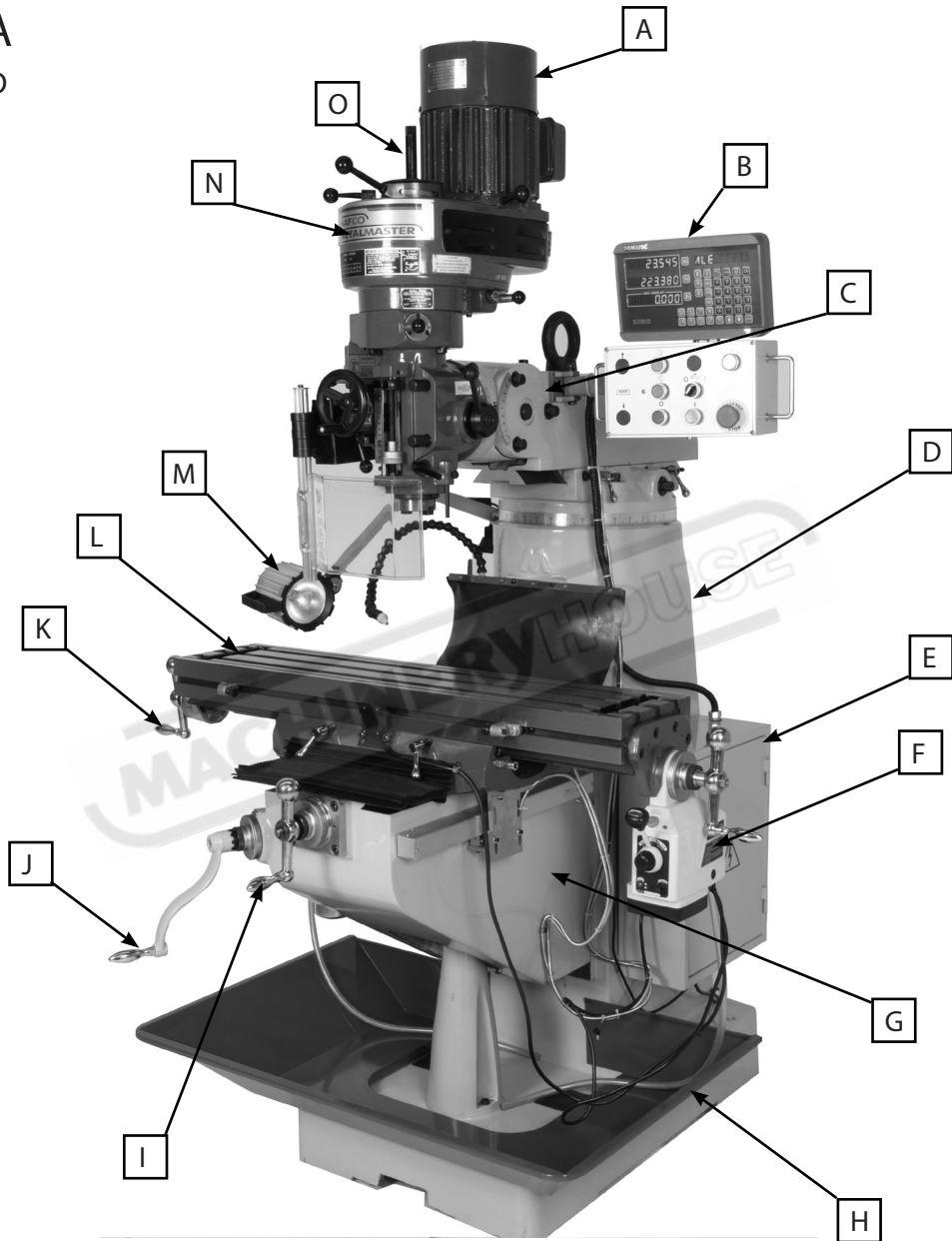

Fig. 1

A	Motor	F	Longitudinal Power Feed	K	Longitudinal Handle
B	Digital Readout	G	Knee	L	Slotted Table
C	Ram	H	Splash Tray	M	Halogen Lamp
D	Main Body	I	Cross Handle	N	Headstock
E	Electrical Cabinet	J	Knee Handle	O	Spindle Drawbar



# OPERATION MANUAL

## BELT DRIVEN HEAD IDENTIFICATION

### BM-23A

Belt Drive Head

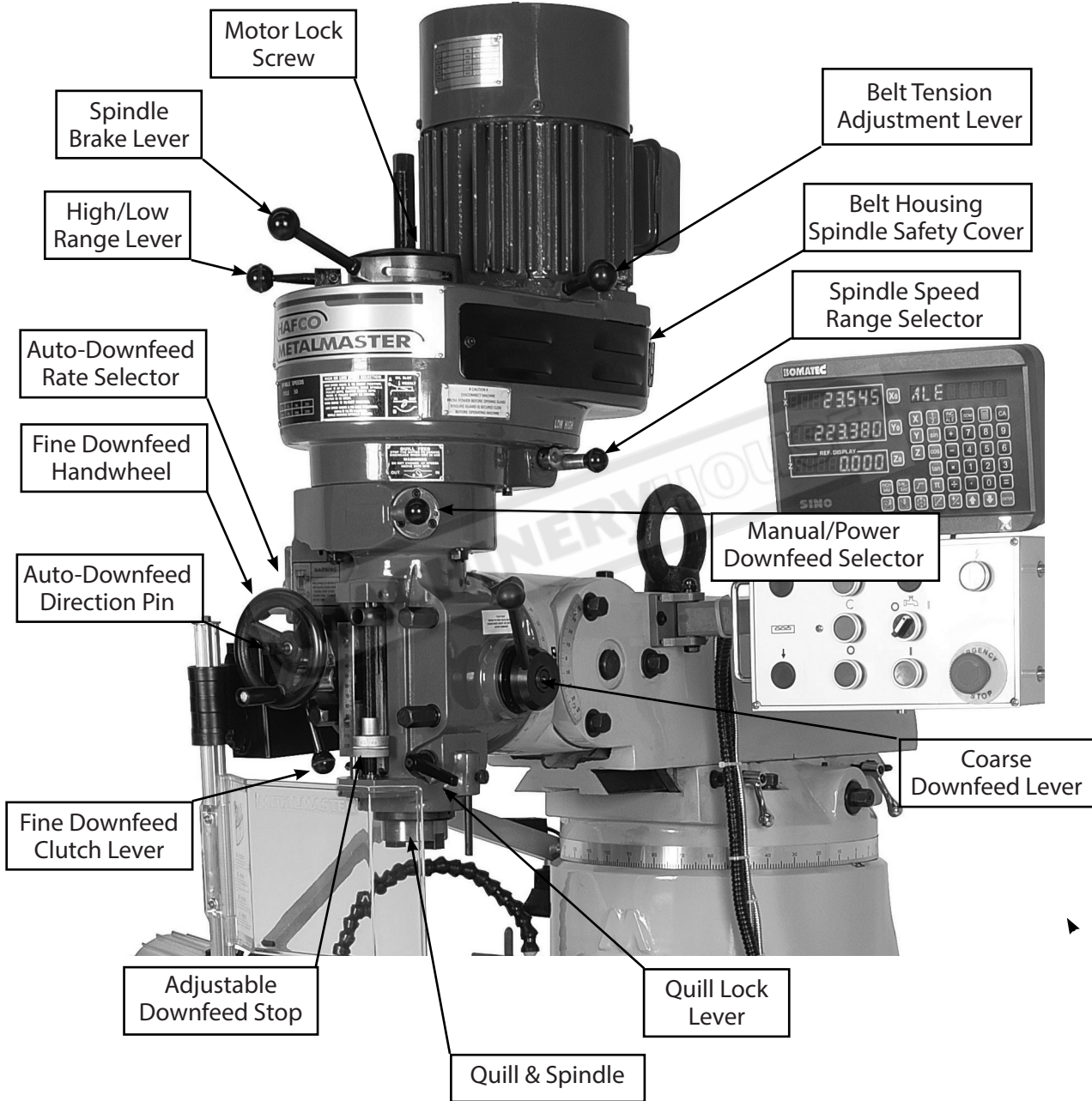

Fig. 2

## OPERATION MANUAL

### CONTROLS AND COMPONENTS FOR THE BM-23A BELT DRIVEN HEAD

The following descriptions are explanations of the items for the belt driven head listed in Fig.2. These will help the operator to become familiar with the basic controls and components of this machine. Understanding these items and how they work will help the operator understand the rest of the manual and stay safe when operating this machine.

**Spindle Brake Lever:** Quickly stops the spindle after power to spindle is turned OFF.

**High/Low Range Lever:** Selects between low (65 RPM–270 RPM) and high (590 RPM–2330 RPM) spindle speed ranges.

**Belt Tension Adjustment Lever:** Adjusts the V-belt tension by moving the position of the motor.

**Motor Lock Screw:** Locks motor position to secure belt tension.

**Belt Safety Cover:** Must be secured closed to protect user from entanglement during operation. Used for access to V-belt when changing spindle speed.

**Spindle Speed Range Selector:** Used in conjunction with high/low range lever. Engages back gear for low (65–270 RPM), and disengages back gear for high (590–2330 RPM) spindle speed ranges.

**NOTE:** When engaged, the back gear reverses the spindle rotation, causing the spindle switch settings to be reversed when in low range

**Manual/Power Downfeed Selector:** Selects between manual and power downfeed.

**Coarse Downfeed Lever:** Quickly moves the quill downward manually and automatically retracts spindle to top position when released. Typically used for drilling operations

**Quill Lock Lever:** Locks the quill in any position for best rigidity

**Adjustable Downfeed Stop:** Limits depth of the quill travel. The dial is graduated in increments of 0.01mm. Typically used for repeat operations.

**Fine/Auto Downfeed Clutch Lever:** Engages fine/auto-downfeed gears.

**Fine Downfeed Handwheel:** Manually controls slow spindle downfeed for fine Z-axis control.

**Auto-Downfeed Direction Pin:** Starts, stops, and reverses the auto-downfeed direction.

**Auto-Downfeed Rate Selector:** Selects one of the three auto-downfeed rates:

0.04 mm/rev

0.08 mm/rev

0.15 mm/rev

**NOTE:**

The correct feed selection depends on the type of material and the number of cutting edges on the tool. Refer to the Fitting and Machining manual (Hafco Code L341)

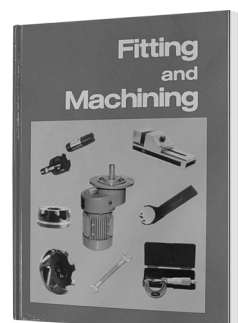

Hafco Order Code **L341**

**VARIABLE SPEED HEAD IDENTIFICATION**

**BM-53VE, BM-63VE**

Variable Speed Head

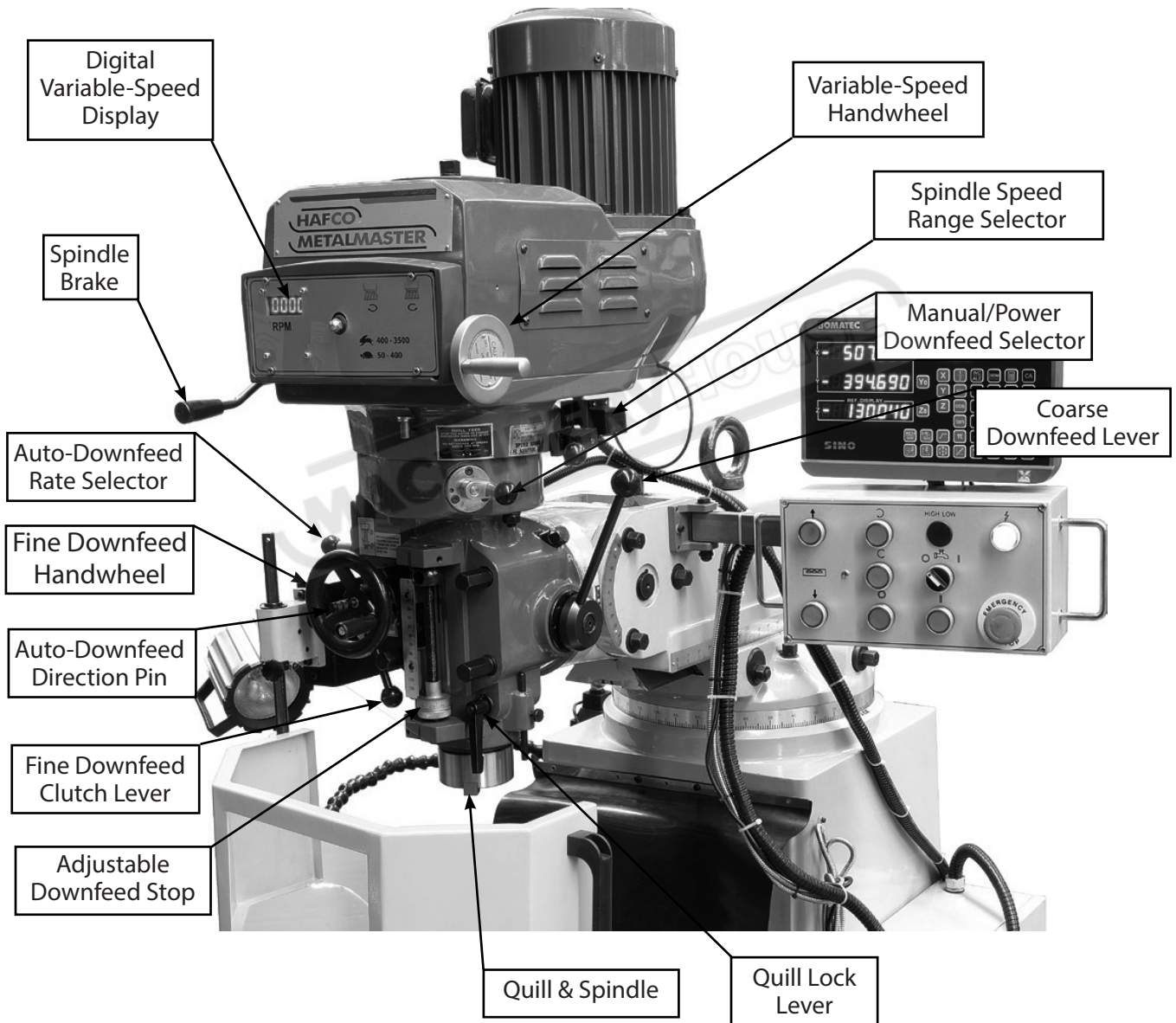

Fig. 3



## OPERATION MANUAL

### CONTROLS AND COMPONENTS FOR THE BM-53VE & BM-63VE VARIABLE SPEED HEAD

The following descriptions are explanations of the items for the variable speed head listed in Fig.3. These will help the operator to become familiar with the basic controls and components of these machines. Understanding these items and how they work will help the operator understand the rest of the manual and stay safe when operating these machines.

**Spindle Brake Lever:** Quickly stops the spindle after the power to spindle is turned OFF.

**High/Low Range Lever:** Selects between low (50 RPM–400 RPM) and high (400 RPM–3550 RPM) spindle speed ranges.

**Spindle Speed Range Selector:** Used in conjunction with high/low range lever. Engages back gear for low (50–400 RPM), and disengages back gear for high (400–3550 RPM) spindle speed ranges.

**Note:** When the back gears are engaged, the spindle rotation, is reversed and the switch settings need also to be reversed in low range

**Digital Variable-Speed Display:** Displays the spindle speed when the machine is in both the high and low range.

**Spindle Speed Range Selector:** Engages back gears for low (50 RPM–400 RPM), and disengages back gears for high (400 RPM–3550 RPM) spindle speed ranges.

**NOTE:** When engaged, the back gears reverse the spindle rotation, causing spindle switch settings to be reversed when in low range

**Manual/Power Downfeed Selector:** Selects between manual and power downfeed.

**Coarse Downfeed Lever:** Quickly moves the quill downward manually and automatically retracts the spindle to top position when released. Typically used for drilling operations

**Quill Lock Lever:** Locks quill in any position for better rigidity

**Adjustable Downfeed Stop:** Limits the depth of the quill travel. The dial is graduated in increments of 0.01mm. Typically used for repeat operations.

**Fine/Auto Downfeed Clutch Lever:** Engages fine/auto-downfeed gears.

**Fine Downfeed Handwheel:** Manually controls slow spindle downfeed for fine Z-axis control.

**Auto-Downfeed Direction Pin:** Starts, stops, and reverses the auto-downfeed direction.

**Auto-Downfeed Rate Selector:** Selects one of the three auto-downfeed rates:

0.04 mm/rev

0.08 mm/rev

0.15 mm/rev

**NOTE:**

The correct feed selection depends on the type of material and the number of cutting edges on the tool. Refer to the Fitting and Machining manual (Hafco Code L341 Page 7)

**TABLE IDENTIFICATION**

Fig. 3.1

- A. X-Axis Ball Handle:** Manually moves table along X-axis (left and right).
- B. X-Axis Locks:** Tightens to prevent X-axis table movement for increased rigidity during operations where the X-axis should not move.
- C. Y-Axis Ball Handle:** Manually moves table along Y-axis (front and back).
- D. Knee Crank:** Manually moves table along Z-axis (up and down).
- E. Y-Axis Lock:** Tightens to prevent Y-axis table movement for increased rigidity during operations where the Y-axis should not move.
- F. One Shot Oiler:** Lubricates X-, Y-, and Z-axis table ways.
- G. Limit Stop:** Restricts table movement by its positioning along front of table.
- H. Direction Knob:** Selects direction of table movement. Middle position is neutral.
- I. Speed Dial:** Controls speed of power feed. Rotating dial clockwise causes the table to move faster.
- J. Rapid Traverse Button:** When pressed, moves table at full speed when already in motion.

## 2. IMPORTANT INFORMATION

### 2.1 SAFETY REQUIREMENTS

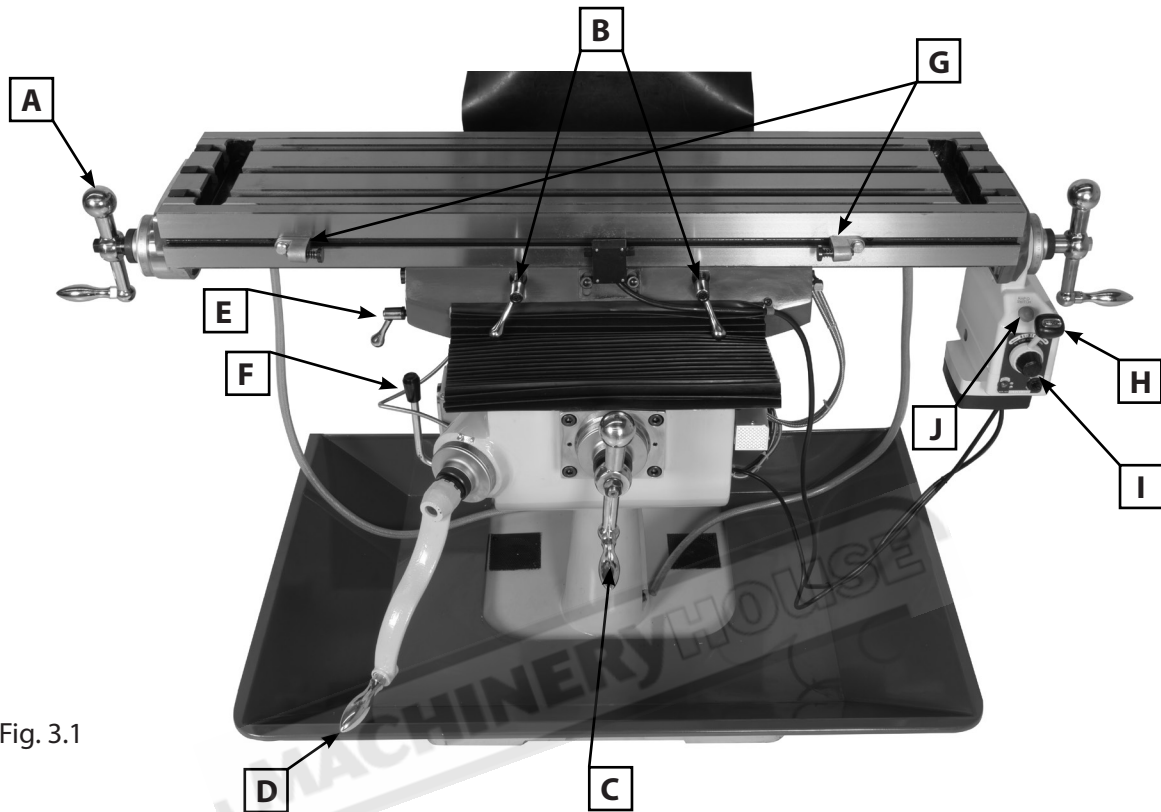
DO NOT use this machine unless you have read this manual or have been instructed in the use of this machine in its safe use and operation



## WARNING

This manual provides safety instructions on the proper setup, operation, maintenance, and service of this machine. Save this manual, refer to it often, and use it to instruct other operators.

Failure to read, understand and follow the instructions in this manual may result in fire or serious personal injury—including amputation, electrocution, or death.

The owner of this machine is solely responsible for its safe use. This responsibility includes, but is not limited to proper installation in a safe environment, personnel training and authorization to use, proper inspection and maintenance, manual availability and comprehension, application of safety devices, integrity, and the use of personal protective equipment.

The manufacturer will not be held liable for injury or property damage from negligence, improper training, machine modifications or misuse.



Safety glasses must be worn at all times in work areas. Earmuffs should be worn if the work area is noisy.



Sturdy footwear must be worn at all times in work areas.



Gloves should not be worn when using this machine. Rings and jewelry must not be worn.



Long and loose hair must be contained with a net or under a hat

**OWNER'S MANUAL.** Read and understand this owner's manual before using the machine.

**DISCONNECT POWER FIRST.** Always disconnect the machine from power supply before making adjustments, or servicing the machine.

This prevents any risk of injury from unintended start-up or contact with live electrical components.

**TRAINED OPERATORS ONLY.** Operators that have not been trained have a higher risk of being seriously injured. Only allow trained or supervised people to use this machine. When the machine is not being used, disconnect the power to the machine to prevent unauthorized use—especially around children. Make the workshop safe.



## OPERATION MANUAL

### 2.1 SAFETY REQUIREMENTS Cont.

**WEARING PROPER APPAREL** Do not wear clothing, apparel or jewelry that can become entangled in moving parts. Always tie back or cover long hair. Wear non-slip footwear to avoid accidental slips, which could cause loss of operating control.

**HEARING PROTECTION.** Always wear hearing protection when operating or observing loud machinery. Extended exposure to this noise without hearing protection can cause permanent hearing loss.

**REMOVE ADJUSTING TOOLS.** Tools left on machinery can become dangerous projectiles upon startup. Never leave chuck keys, wrenches, or any other tools on machine. Always verify removal before starting!

**USE CORRECT TOOL FOR THE JOB.** Only use this tool for its intended purpose. Do not force the machine or its attachments to do a job for which they were not designed. Never make unapproved modifications. Modifying the machine or using it differently than intended may result in malfunction or mechanical failure that can lead to personal injury or death!

**AWKWARD POSITIONS.** Keep proper footing and balance at all times when operating machine. Do not overreach! Avoid awkward hand positions that make operating control difficult. This could increase the risk of accidental injury.

**CHILDREN & BYSTANDERS.** Keep children and bystanders at a safe distance from the work area. Stop using machine if they become a distraction

**GUARDS & COVERS.** Guards and covers reduce accidental contact with moving parts or flying debris. Make sure they are properly installed, undamaged, and working correctly.

**ELECTRICAL EQUIPMENT INJURY RISKS.** There is a risk of being shocked, burned, or killed by touching live electrical components or improperly grounded machinery. To reduce this risk, only allow qualified service personnel to do electrical installation or repair work, and always disconnect power before accessing or exposing electrical equipment.

**FORCING MACHINERY.** Do not force the machine. It will do the job safer and better at the rate for which it was designed.

**NEVER STAND ON MACHINE.** Serious injury may occur if the machine is tipped or if the cutting tool is unintentionally contacted

**STABLE MACHINE.** Unexpected movement during operation greatly increases risk of injury or loss of control. Before starting, verify machine is stable and if using a mobile base make sure it is locked in position

**USE RECOMMENDED ACCESSORIES.** Consult this manual or the manufacturer for recommended accessories. Using improper accessories will increase the risk of serious injury.

**UNATTENDED OPERATION.** To reduce the risk of accidental injury, turn the machine OFF and ensure all moving parts have completely stopped before walking away. Never leave the machine running while unattended.

**MAINTAIN WITH CARE.** Follow all maintenance instructions and lubrication schedules to keep the machine in good working condition. A machine that is improperly maintained could malfunction, leading to serious personal injury or death.

**CHECK DAMAGED PARTS.** Regularly inspect the machine for any condition that may affect the safe operation. Immediately repair or replace damaged parts or parts that are incorrectly fitted before operating.

**MAINTAIN POWER CORDS.** When disconnecting the cord-connecting the machines from the power, hold and pull the plug—not the cord. Pulling the cord may damage the wires inside. Do not handle cord/plug with wet hands. Avoid cord damage by keeping it away from heated surfaces, high traffic areas, harsh chemicals, and wet/damp locations.

**CLEARING CHIPS.** Metal chips can easily cut bare skin—even through a piece of cloth. Avoid clearing chips by hand or with a rag. Use a brush or vacuum to clear metal chips.

## OPERATION MANUAL

### SET-UP AND INSTALLATION

#### Preparing the Milling Machine for Service

1. Remove any crating which may be covering the machine on the pallet.
2. Remove from the pallet the toolbox and any other items shipped separately with the machine. Inside the toolbox are the fine and coarse feed handles, along with other tools.
3. Check that the eye bolt on the ram is tight.
4. Check that the lock handles on the ram are locked tight.
5. Remove the nuts and/or bolts, which secure the machine to the pallet.
6. Center the overhead lifting device and sling using the eye bolt.

**NOTE:** Be sure that the lifting slings and crane have the capacity to handle the lift. When lifting using the eye bolt, the machine will tip forward. A sling attached to the front of the machine will help stabilize the machine. Be careful when doing this, to prevent the sling from damaging any components on the front of the machine.

7. Lift the machine off the pallet no higher than necessary, then pull the pallet out of the way. **DO NOT** put hands or feet underneath the machine when removing the pallet!
8. Lower the machine over the area where the machine is to sit and mark where the hold down bolts are to be set.

**NOTE:** Check that the maximum dimensions of the machine with the table, ram, etc., fully extended in all possible directions. Be certain to leave clearance not only for the machine itself, but also for operating, servicing the machine, and any unusual sizes of workpieces that might extend off the machine's table.

#### Leveling the Machine

9. When the machine is over its anchors, level the machine using shims under the corners that need them. (Fig. 4) A machinist's level, placed on the table should be used for leveling. The table is the reference surface for both side-to-side and fore-and-aft leveling. Be certain you get it level in BOTH directions.
10. When the machine is level, secure the base with the masonry anchors.
11. Loosen the four hex head nuts that secure the head to the ram. (about 1/4 turn each, just enough to allow rotation of the head). (See adjustments Page 22)
12. While assisting the worm mechanism by putting upward pressure on the motor by hand, use the wrench supplied with the machine to turn the worm nut and raise the head to upright position.
13. Tighten the headbolts slightly — not torqued — just snug.
14. Using mineral spirits or other non-flammable cleaning solvent, clean all of the rust proofing from where it may have been applied. This is important as moving the table or any other component before removing the rust proofing will only put rust proofing where you don't want it. Some of the following steps may have already been performed on the machine. If so, ignore the instructions related to these steps. Otherwise, perform them in the order listed.
15. Install the table end and cross-feed handles on their respective shafts using the nuts on the shafts to secure them.
16. Remove any rust proofing from the drawbar and its washer, and put the drawbar with washer installed into the spindle center through the top of the machine.
17. Slide the fine feed handwheel over the handwheel hub and push it back until its roll-pin engages the hole in the hub and the wheel is flush with the hub surface.
18. Put the coarse feed lever on the feed shaft and tap it lightly until its roll-pin engages a hole in the hub and it is flush against the hub surface.
19. Unwrap and clean the knee crank and install it on its shaft.

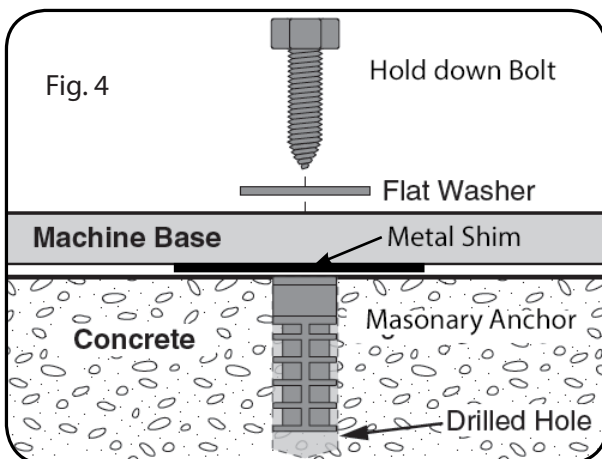

## SET-UP AND INSTALLATION

### Removal Of Mill Head Block

Before shipment, the mill head is rotated to the side to lower the machine center of gravity. A wooden block is placed between the mill head and the worktable to support the head. The block is removed by raising the mill head. Before attempting to raise the mill head, refer to Mill Head – Left/Right Adjustment in the Setup section (Page 22) for procedures to safely raise and setup the mill head.

### Electrical Connection



## WARNING

**All electrical connections must be made by a qualified electrician! Failure to comply may cause serious injury!**

Confirm power at the site matches the power requirements of the mill before connecting to the power source.

### Electrical Requirement

**BM-23V Single Phase 240Volt 15amp**  
**BM-53V 3 Phase 415 Volt 20 amp.**  
**BM-63V 3 Phase 415 Volt 20 amp**

Before connecting to the power source, make sure that the switch is in the off position.

The mill must be properly grounded in accordance with electrical standards.

Check for proper spindle rotation in the high-speed range. The spindle should rotate clockwise when viewed from the top of the machine. If the spindle rotates counter-clockwise, advise the qualified electrician to change the rotation.

### Extension Cords

We do not recommend using an extension cord with this machine. If you must, only use it if absolutely necessary and only on a temporary basis. Extension cords cause voltage drop, which can damage electrical components and shorten motor life. Voltage drop increases as the extension cord size gets longer.

## OPERATING INSTRUCTIONS

### Operating Controls

The lubrication system is a manually operated, one-shot system requiring operator intervention. The operator must lower the one-shot lever to lubricate the machine ways and lead screw or ballscrews. The one-shot lubrication system reservoir is located on the left side of the machine. The position of the milling machine mill head can be set up to accommodate the work piece being machined. The mill head can be set up for angles to the left or right and for fore and aft angles. The mill head can also be rotated on its turret. The ram can be moved back and forth to reach work piece locations at the fore and aft extremes of worktable travel. Refer to the Adjustments section. (Page 22)

### Motor Switch

The Motor Switch is on the upper left-hand side of the mill head (B, Fig 4.1). The switch has three positions: FWD (forward), OFF, and REV (reverse). Setting the switch to FWD will provide clockwise spindle rotation. Use FWD for normal, right-hand tooling

When the gearbox is in the low speed position the motor switch must be in the REV position for clockwise operation to occur. When the gearbox is in high-speed position, the motor switch must be in the FWD position to provide right-hand or clockwise rotation. Refer to Fig. 5 for a chart of required switch positions.

The motor switch controls the motor. The motor can be switched from FWD to REV when the motor has stopped, and will reverse direction when the switch setting is changed.

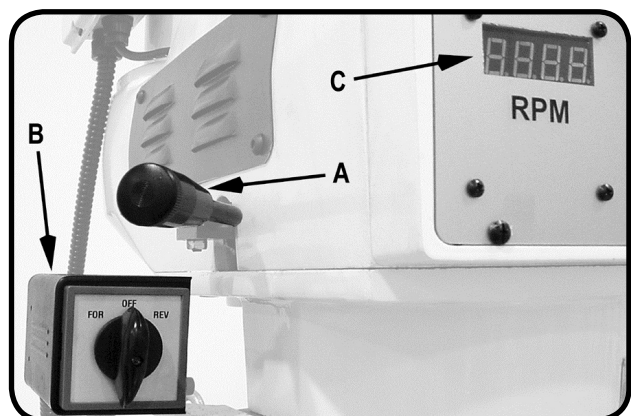

Fig. 4.1

**SETTING BM-23A SPINDLE SPEED**

The Model BM-23A has eight spindle speeds—four in low motor speed and four in high motor speed. Setting the spindle speed involves: 1) Selecting the spindle speed range, 2) positioning the V-belt, and 3) setting the spindle switch.

**To Set The Spindle Speed:**

1. DISCONNECT MACHINE FROM POWER!
2. Use chart below or spindle speed chart on headstock to find appropriate spindle speed for your operation (see Fig. 4.2).

Fig. 4.2

SPINDLE SPEED CHART					
		1 2 3 4			
		SPINDLE PULLEY MOTOR PULLEY			
SPEED RANGE	BELT POSTION				
	1	2	3	4	
LOW	65	110	180	270	
HIGH	590	975	1550	2330	

3. Pull the spindle speed range selector knob (see Fig. 4.3) out, position either in HIGH or LOW range, then release knob to seat knob pin in detent. **NOTE:** If it is difficult to move range selector knob, rotate spindle by hand to help mesh the gears until selector moves freely.

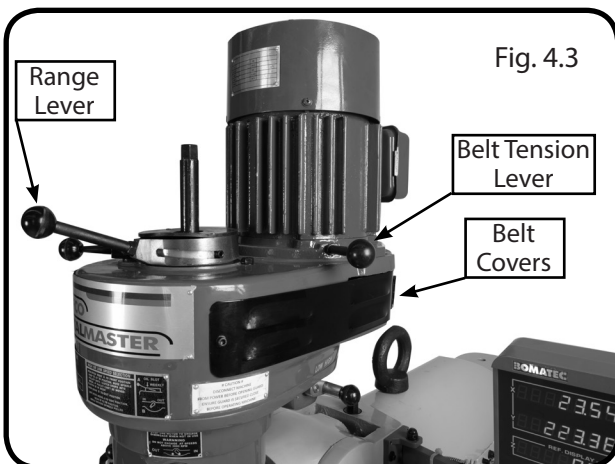

Fig. 4.3

4. Lever 1 is shown in Fig. 4.4 in the HIGH or LOW position

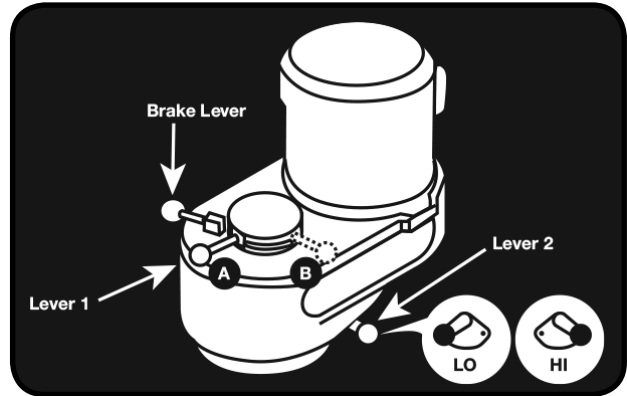

Fig. 4.4

**NOTE:** If this step was not successful, use HIGH/LOW range lever (Lever 2 Fig. 4.4) to reset speed range, then repeat this step until you are certain that spindle is seated into spindle clutch.

5. Remove belt housing side covers on either side of head to expose V-belt and pulleys, as shown in Fig. 4.3
6. Loosen two motor lock levers, one on each side of head, then pull belt tension adjustment lever forward to release V-belt tension (see Fig. 4.3).
7. Refer to spindle speed chart on front of headstock (see Fig. 4.2), and position V-belt on pulleys for desired spindle speed.
8. Push adjustment lever backward with moderate force to re-tension V-belt, then re-tighten two lock levers to secure motor
9. Replace two belt housing side covers before re-connecting mill to power



OPERATION MANUAL

Control Positions for Milling and Drilling Operations

Control \ Action	High/low lever	Quill feed lever	Feed trip cam lever	Quill feed select lever	Feed direction control	Motor switch*
High spindle speeds						REV
Low spindle speeds						FWD
High spindle speeds with automatic downfeed				Select feed rate		REV
Low spindle speeds with automatic downfeed				Select feed rate		FWD
High spindle speeds with automatic upfeed				Select feed rate		REV
Low spindle speeds with automatic upfeed				Select feed rate		FWD
Lever feed						
Fine feed using handwheel						
Free-turning spindle for positioning or working with tooling						

Fig. 5

Speeds at Specific Control Settings

Hi/low speed control lever	Range of speeds using control wheel
	50 - 400 RPM
	400 - 3300 RPM

\* Motor switch position is for right-hand tooling (tooling which requires clockwise rotation of the spindle.) If you are using left-hand tooling, simply change the motor switch to the opposite setting.

SETTING VARIABLE HEAD SPEEDS



With the variable speed head change the speed only when the spindle is turning. The variable speed handwheel is used to control the spindle speed. The handwheel is located on the right side of the mill head. The speeds for high and low speed ranges are displayed on the panel on the front of the mill head (B, Fig. 6). All speed changes must be made while the motor is running. Attempting speed changes with the motor not running can result in damage to the drive mechanism.

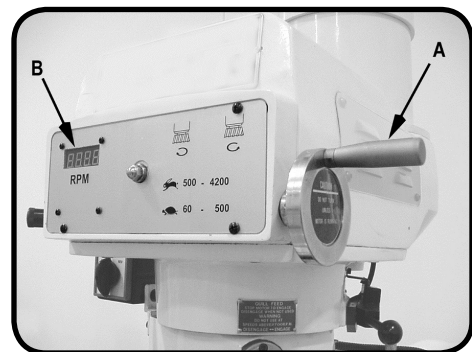

Fig. 6



**Variable Speed Control**

**Hi Speed:** move the handle (Fig 6-1 , A,) on the front of the top of the head. Move the handle B (Fig 6-2 B) to the IN position. Rotate the spindle nose by hand until the gears mesh with the clutch. Move the handle B to the OUT position( Fig 6-2,B)

**Low-Speed:** move the handle A lever from the top of head, then move the handle B to the IN position

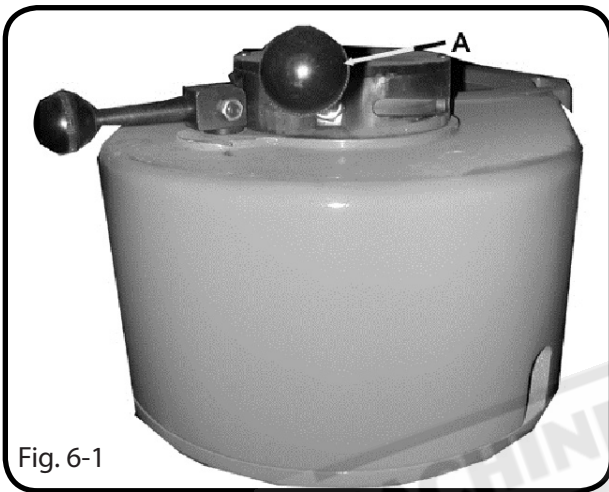

Fig. 6-1

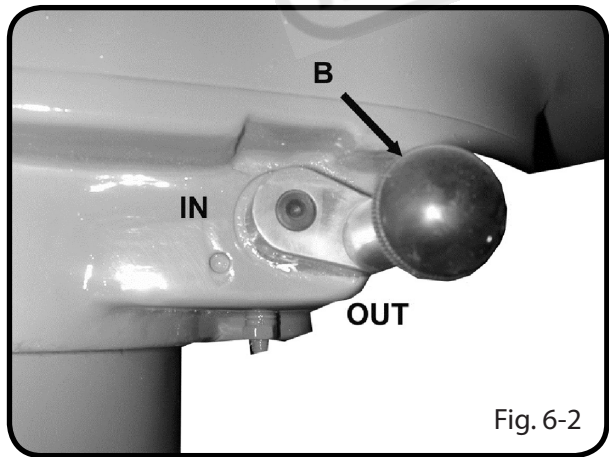

Fig. 6-2

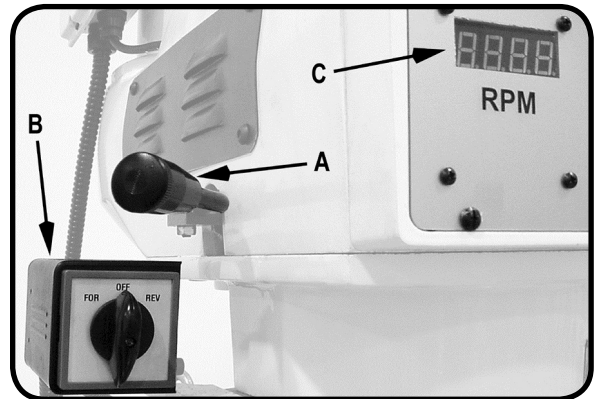

Fig. 7

**High-Neutral-Low Shift Lever**

The mill head can be driven directly (High Speed) or through the back gears (Low Speed) in the mill head. The selection is made by changing the position of the shift lever.

The shift lever is located at the lower right side of the mill head (Fig. 8). The lever position closest to the operator is the High setting. The lever position away from the operator is the Low setting. The middle position is the Neutral setting.

**CAUTION**

Do not shift the High-Low Gear Lever while the motor is running. Rotate the spindle by hand while changing the lever



Fig. 8

**Spindle Brake**

The spindle brake lever is located on the upper left side of the mill head ( A. Fig. 7). Pull lever downward to apply the brake. The spindle brake is used only after the motor switch has been set to OFF. The spindle will not stop with the motor running.

### Quill Feed Lever

#### CAUTION

Do not use the quill power feed at speeds above 2700 R.P.M. It is recommended to disengage the power feed worm gear whenever the power feed is not required. This avoids unnecessary wear on the worm gear.

#### CAUTION

Do not move the Quill Feed Lever unless the motor is at a complete stop. When changing the lever position, do it gently. The quill feed lever is located on the right side of the mill head (Fig. 9). It is used to engage and disengage the quill power feed mechanism. The quill feed is engaged by pulling out the knob and rotating the handle to a new locked position. When engaged, the power feed mechanism will drive the spindle upward or downward. The power feed mechanism will not drive the spindle when the handle is in the disengage position.



Fig. 9

### Feed Rate Lever

The Feed Rate Lever (Fig. 10) is used to set the quill feed per-revolution rate. Three feed rates are available: 0.04mm, -0.08mm, and 0.15mm per revolution. The positions are shown on an indicator plate under the feed rate lever.

The rate is selected by pulling out the knob on the feed rate lever and moving the handle to the detent of the desired feed rate.

**NOTE:** The knob is spring loaded – pull out to rotate to new position. Unlike other controls on the machine, the lever shifts into engagement more easily with the motor running, and the quill feed lever engaged

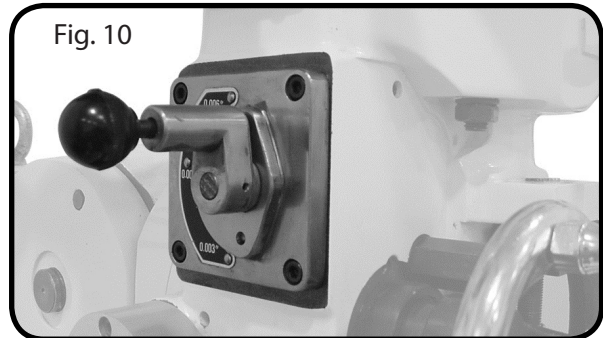

Fig. 10

### Feed Clutch Lever

The Feed clutch Lever (A, Fig. 11) is located on the left side of the head behind the Manual Fine Feed Handwheel (B, Fig. 11). It engages the overload clutch on the pinion shaft when positioned to the left. The Feed Clutch Lever stays engaged until Quill Stop (C, Fig. 14) comes in contact with Micrometer Adjusting Nut, forcing it to drop out automatically, or until the operator releases it manually by moving the lever to the right.

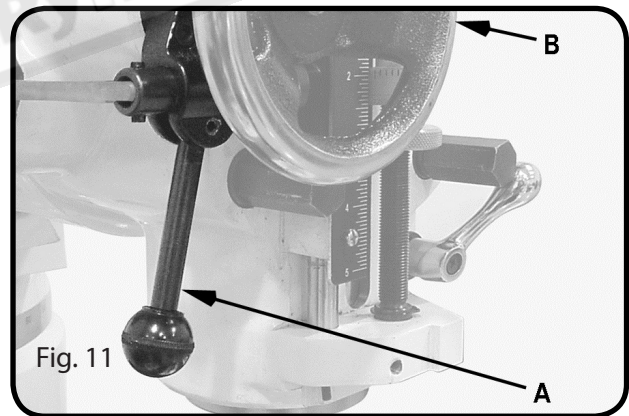

Fig. 11

### Feed Direction Control

The Feed Direction Control (B, Fig. 12) determines whether the power feed will move up, down, or not move at all. The position of the knob depends upon the direction of spindle rotation (see the Motor Switch section). The position of the control may be changed with either the motor stopped or running. If the control does not engage easily, move the fine feed handle (A, Fig. 12) back and forth to aid engagement.

If the spindle is rotating clockwise, the IN position is downfeed; The OUT position is upfeed. When the spindle is reversed the feed will also reverse. The neutral position is between the IN and OUT position

**CAUTION**

It is recommended that the Feed Direction Knob be left in the neutral position when not in use.

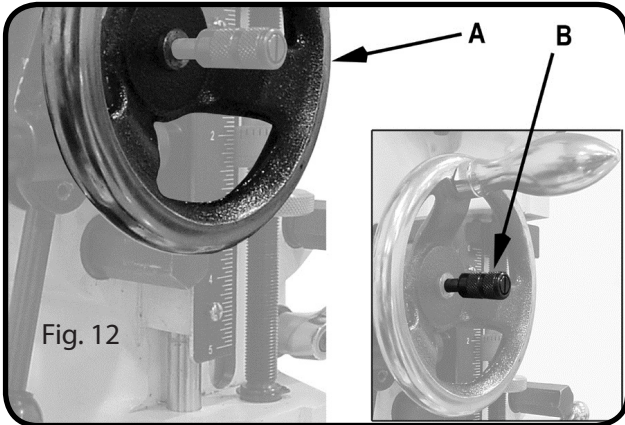

Fig. 12

**Coarse Feed Handle**

The Coarse Feed Handle (A, Fig. 13) is located on the right hand side of the head. The Coarse Feed Handle is used for non-precision drilling operations, or for moving the quill to a specific depth, against the quill stop knob.

**Quill Lock Lever**

The Quill Lock Lever (B, Fig. 13) is located on the right side of the head. Rotate the handle clockwise to lock the quill in a desired position. Rotate the handle counter-clockwise to release. The Quill Lock Lever (B, Fig. 13) is used to lock the quill at a specific depth.

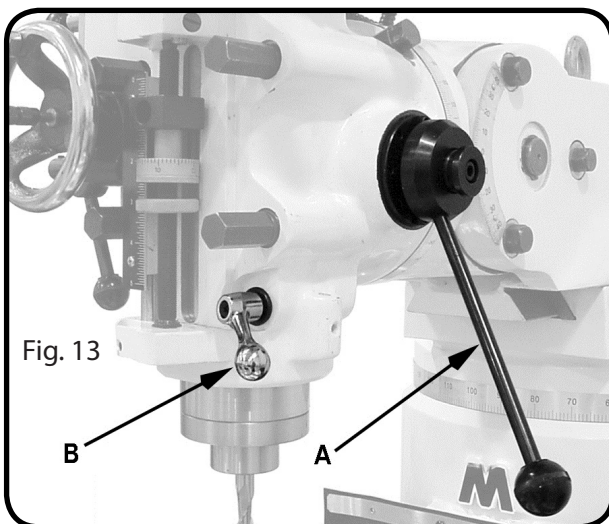

Fig. 13

**Micrometer Adjusting Nut**

The Micrometer Adjusting Nut (A, Fig. 14) is located on the front of the head and is used for setting specific spindle depths. It is secured with the lock nut (B, Fig. 14).

**Fine Feed Wheel**

When the controls are set for the Fine feed using handwheel position (Figure 5), the Fine Feed Handwheel (A, Fig. 12) can be used to manually control the upward or downward direction of the quill.

**WARNING**

Remove the Manual Fine Feed Handwheel when not in use. Failure to comply may cause serious injury.

**Depth Scale and Stop**

The Depth Scale and Stop are used during the drilling operations to set the depth of the drilled hole. The depth scale is located on the front of the mill head. The scale consists of a Micrometer Adjusting Nut (A), Lock Nut (B), Quill Stop (C), Quill Stop Screw (D), and Scale (E).

The Micrometer Adjusting Nut is set to the desired dimension and locked in place using the Lock Nut. The quill stop provides a positive stop for quill travel. The graduations on the micrometer nut are in 0.01mm increments. Adjustment of quill travel is made by rotating the micrometer nut. (Refer Fig. 14:)

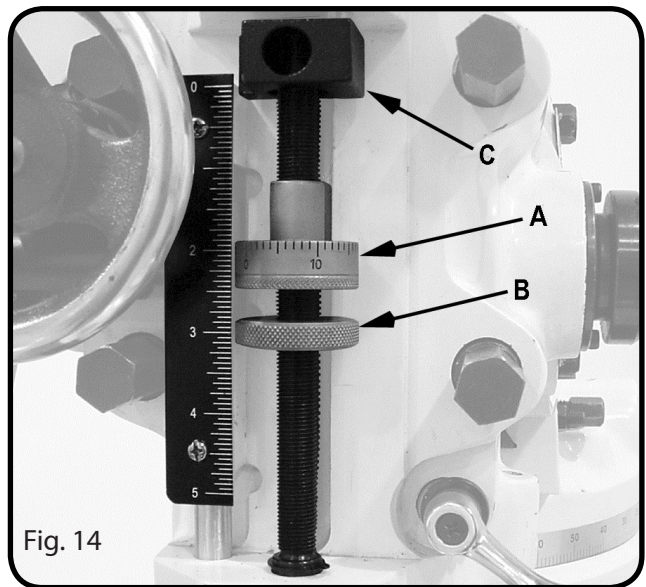

Fig. 14

### Spindle Downfeed Operation

The Feed Trip Adjustment sets the point at which the quill will reset during Power Feed.

Referring to Fig. 16:

The Manual Fine Feed Handwheel can be removed, but if not removed care should be taken when the auto feed is used so as not to make contact with the wheel while it is turning.

1. Loosen the Locknut (J).
2. Using the Quill Feed Handle (K), advance the quill to the point where the feed should stop.
3. Engage the Feed Trip Cam Lever (D) by pulling away from head assembly.
4. Adjust Micrometer Adjusting Nut (I) against Quill Stop (H).
5. Continue turning the Micrometer Adjusting Nut (I) until the Feed Trip Cam Lever (D) trips.
6. Tighten the Locknut (J).
7. Ensure the Quill Lock (L) is off by rotating counter clockwise.
8. Turn the spindle on (A):  
FWD rotates the spindle counterclockwise.  
REV rotates the spindle clockwise.
9. Select the feed rate with the Variable Speed Control Handwheel (F).
10. Set the Feed Rate Lever (Fig. 17) to the feed rate required for the tooling and material required.
11. Position auto-downfeed direction pin (see "C" Fig. 16) in center of handwheel for spindle travel that is correct for your operation. If necessary, rock fine downfeed handwheel back-and-forth to move pin all the way in or out.
12. Select feed direction by setting the Feed Direction Knob (C) position per the table:

**NOTE:** The direction pin has three positions:

- 1) In for one downfeed direction,
- 2) middle for neutral or no movement,
- 3) out for the reverse direction. The direction of spindle travel for the in and out positions is relative to the direction of spindle rotation. Keep in mind that spindle rotation and downfeed direction will reverse when the spindle speed range is changed.

13. Engage the Feed Trip Cam Lever (D) by pulling away from head assembly.

**NOTE:** Due to variables in tool diameter, coatings, coolant, and materials, no specific spindle speed or feed rate recommendations are provided. Refer to Fitting and Machining manual ( Hafco Code L341) or a general shop manual that has data applicable to the milling and drilling operations being performed.

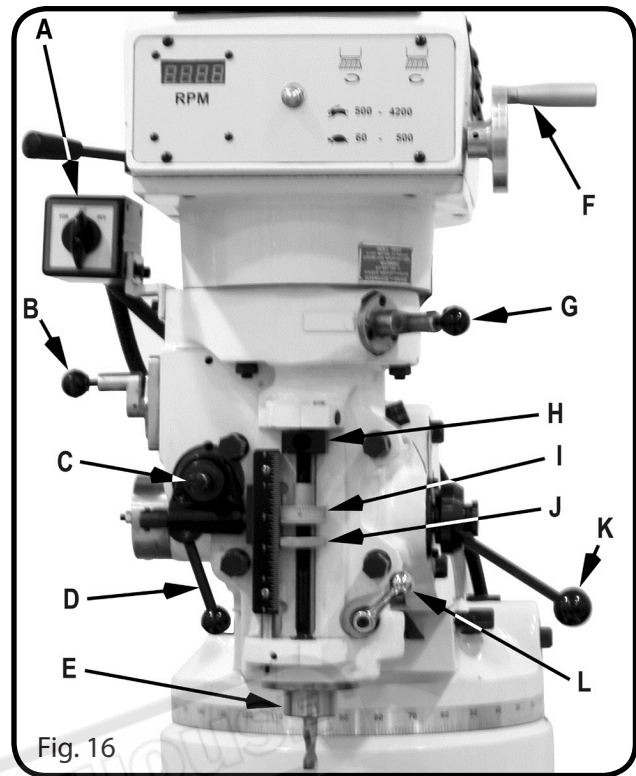

Fig. 16

Spindle Direction	Feed Direction	Knob Position
Clockwise	Down	In
	Up	Out
Counter Clockwise	Down	Out
	Up	In

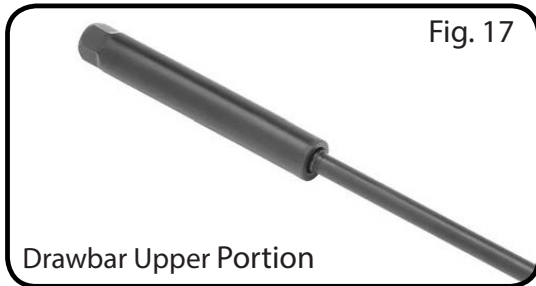

Fig. 17

## OPERATION MANUAL

### LOADING & UNLOADING TOOLING

These mills are equipped with a NT-30 spindle taper (BM-23A) with an 12mm drawbar and a NT-40 spindle taper (BM-53VE, BM-63VE) with a M16 spindle drawbar (Fig. 17)



#### Loading Tooling

1. DISCONNECT MILL FROM POWER!
2. Clean any debris or surface substances from inside the spindle taper and the mating surface of the tooling.

**NOTE:** Debris or oily substances can prevent the tooling and spindle from properly mating. This condition can cause excessive vibration, poor cutting results, or tool/work-piece damage.

3. Place the mill in the low spindle speed range to keep the spindle from turning or use the spindle brake in the next steps. (B of Fig. 18)
4. With one hand holding the tool in place, insert the drawbar into the spindle from the top of the head, then thread it into the tool (see A of Fig. 18)

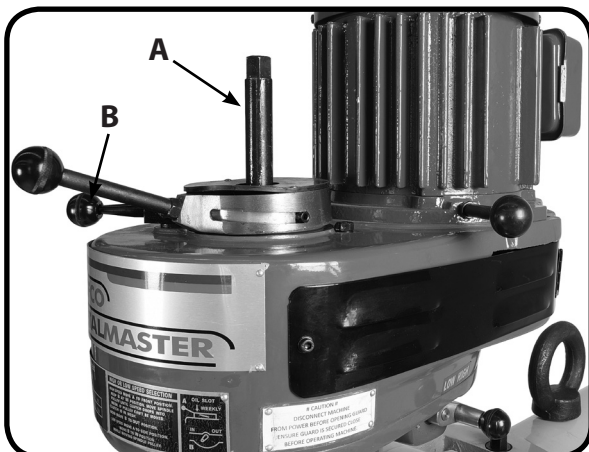

Fig. 18

5. Tighten the drawbar until it is snug. Avoid overtightening, as this could make removing the tool difficult

**NOTE:** Make sure that the drawbar has at least three threads engaged with the tooling in the next step to avoid damaging the threads of the drawbar or tool.



Fig.19

#### UNLOADING TOOLING

1. DISCONNECT THE MILL FROM POWER!
2. Place the mill in the low spindle speed range to keep the spindle from turning in the next step.
3. Loosen the drawbar a couple of turns, then tap the top of it with a brass hammer to knock the tool loose at the bottom of the spindle.
4. Support the tool with one hand, then completely unthread the drawbar from the tool.

## ADJUSTMENTS

### Positioning Headstock

The head tilts 45° forward or backward and rotates 90° left or right (see Fig. 19, 20 ). Any time the head has been tilted or rotated, you must square the spindle with the table when setting the headstock back to the 90° position. This is the only way to ensure precision milling results later.

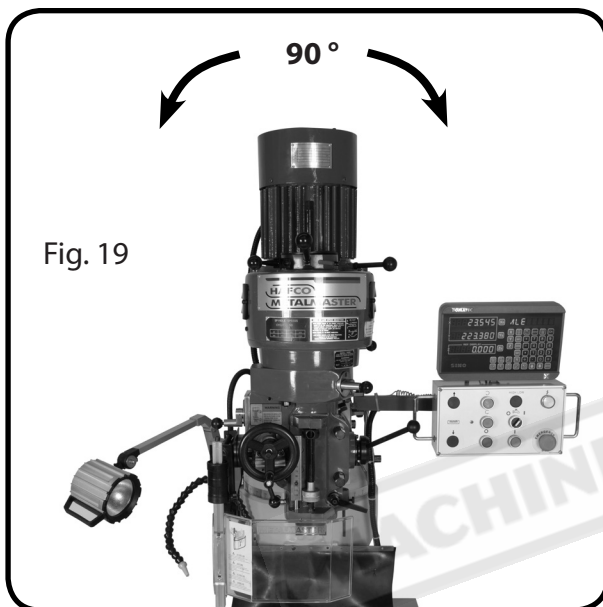

Fig. 19

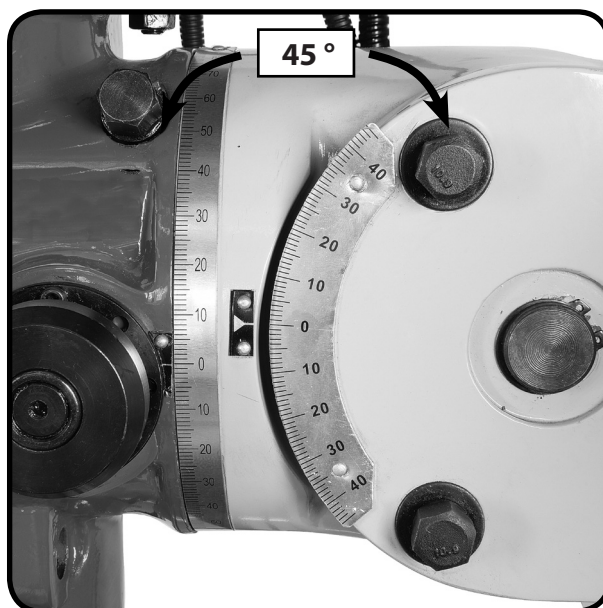

Fig. 20

### Tilting Head Forward/Backward

1. DISCONNECT MACHINE FROM POWER!
2. Loosen three lock bolts "A" shown in Fig.21
3. Use one hand to apply pressure to head in direction of tilt, then slowly rotate tilt-bolt "B" shown in Fig. 21

**NOTE:** Rotate tilt-bolt clockwise to tilt head backward and counterclockwise to tilt it forward.

4. Re-tighten lock bolts

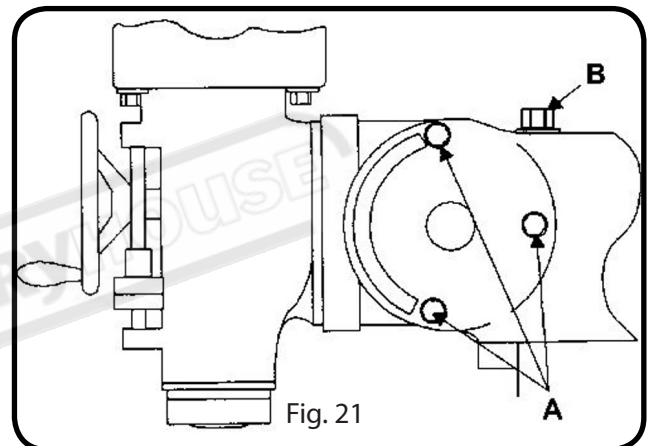

Fig. 21

### Rotating Head Left & Right

1. DISCONNECT MACHINE FROM POWER!
2. Loosen four lock bolts "A" shown in Fig 22, 23 half a turn only.

**NOTE:** Do not completely remove the four lock bolts as the head will fall off and may cause injury. Check your model number for the position of the 4 bolts.

3. Use one hand to apply pressure to head in direction of rotation, then slowly turn rotation bolt "B" shown in Fig. 22 or 23.

**NOTE:** Turn rotation bolt clockwise to rotate head left and counterclockwise to rotate it right.

**OPERATION MANUAL**

**NOTE:** The lock bolts shown in Fig. 22, 23 are threaded into T-nuts that travel in a circular slot during head rotation. When rotating the head, it is possible for these T-nuts to jam in the slot preventing movement of head. If this happens, gently rotate each lock bolt, starting with the lower right, until you free up the jammed T-nut. Then continue to rotate head to desired position.

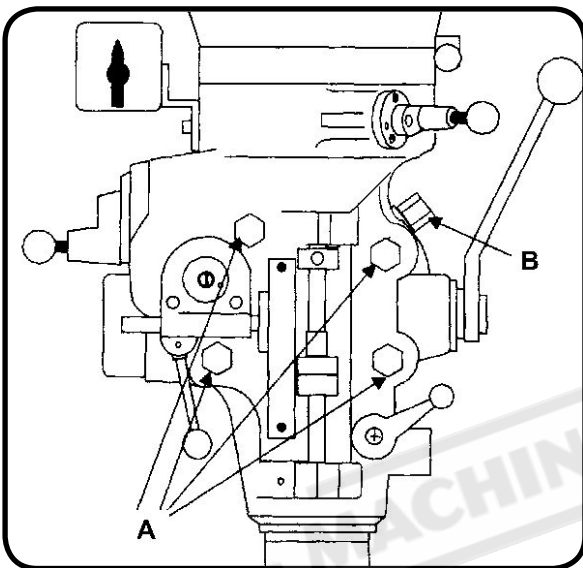

BM-23A  
BM-53VE

Fig. 22

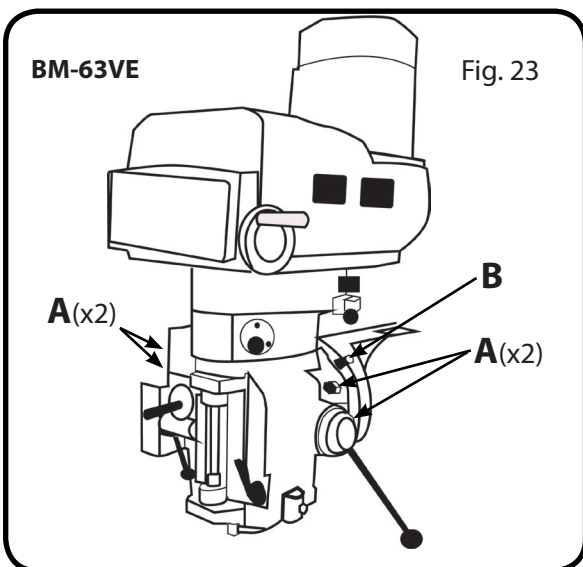

BM-63VE

Fig. 23

**NOTE:** Be sure to apply torque in two steps using a crossing pattern. Failure to do so could distort the face of the ram adapter.

4. Tighten the four hex nuts (A). Tighten in two steps using a calibrated torque wrench. Tighten initially to 25 foot-pounds, then tighten the four hex nuts to a final torque of 50 foot-pound

**Returning to Upright Position:**

1. Check to make sure the mill head is square to the worktable, by setting up a dial indicator in a collet or with a magnetic base on the spindle
2. Put the spindle drive in neutral and rotate the spindle 180 degrees (when rotating, raise the indicator plunger to prevent it from dropping into the table T-slots (Fig. 24)
3. The indicator should read the same in position "C" and "D" (Fig. 24) of the table. If not, loosen the four hex nuts (A of Fig. 22) and reposition the mill head. If the indicator does not read the same in "E and "F" (Fig.24) loosen the nuts "A" in Fig. 21 and reposition the mill head.

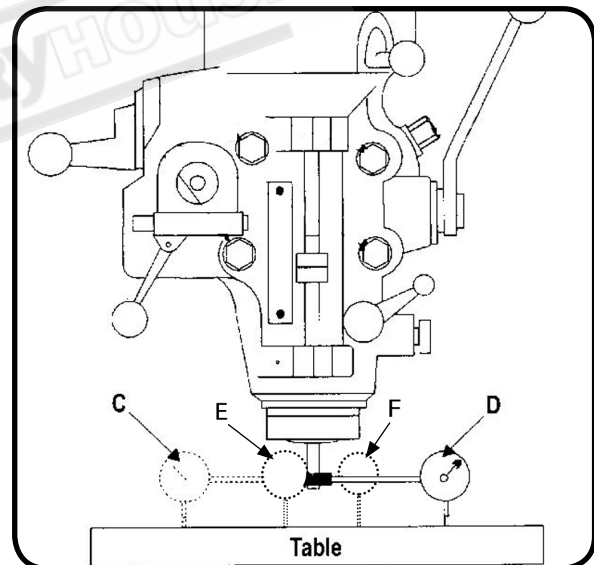

Fig. 24

**NOTE:**

**Always lock head firmly in place after tilting or rotating it. Unexpected movement of head during operations could cause damage to cutter or workpiece.**

## POSITIONING THE RAM

### Positioning the Ram Forward and Backward

1. DISCONNECT MACHINE FROM POWER
2. Loosen the two bolts (A, Fig. 25) that lock the ram to its ways.

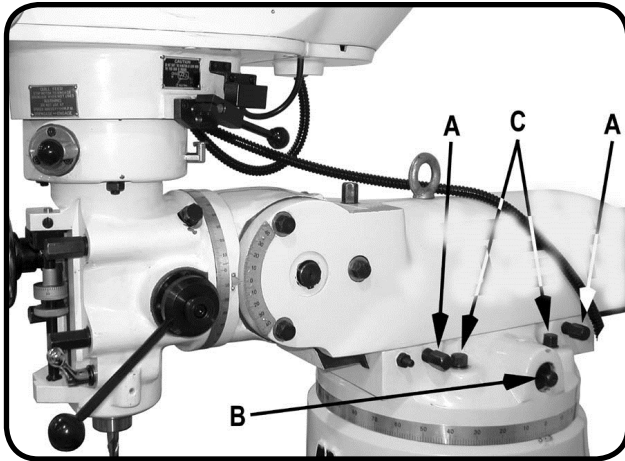

Fig. 25

3. Make sure there are no obstructions to ram travel, especially any tooling around workpiece, then slowly rotate adjustment bolt "B" Fig. 25. to move ram.

**NOTE:** Rotate bolt clockwise to move ram away from table and counterclockwise to move ram toward table.

4. When the desired position is reached, lock the bolts (A, Fig. 25) securely.

### CAUTION

Always lock head firmly in place after tilting or rotating it. Unexpected movement of head during operations could cause damage to cutter or workpiece.

### Rotating the Ram on its Turret

The ram rotates 360° around the turret, as well as traveling forward or backward. To rotate the ram on the turret see the following.

Make sure the machine base is secured to the floor before repositioning the ram.

1. DISCONNECT MACHINE FROM THE POWER!
2. Loosen four turret lock bolts (C, Fig. 25) that clamp the ram to the top of the base. A half a turn should be sufficient to allow the ram to move.

**NOTE:** There are two lock bolts on each side of the ram. Use gentle hand pressure to avoid rapid movement.

**NOTE:** In the next step, take care not to entangle or stretch electrical cabling as you move ram around turret.

3. Push head to manually rotate ram. Use rotation scale (D on Fig. 26) to determine correct position for your operation, then re-tighten four lock bolts to secure ram in place.



Fig. 26



## OPERATION MANUAL

### MAINTENANCE

Before any maintenance is carried out on the machine, disconnect it from the electrical supply by removing the plug or switching off the main switch! Failure to comply may cause serious injury.

#### Lubrication

The milling machine is equipped with a "one-shot" lubrication system. The system lubricates the lead screws and ways. Grease cups on the mill head provide lubrication for the spindle bearings and back gear mechanism. Refer to Fig. 26 for lubrication requirements and Fig. 28 for lubrication points.

Key	Description	Lubricant	Action
A	Spindle bearing oil cup	SAE 10 or 10W spindle oil	Service daily
B	One-shot lube system	MOBIL Vectra #2 way lube	Check oil daily – add if required. Pull lube handle every hour.
C	Knee lead screw	MOBIL Vectra #2 way lube	Service fitting weekly
D	Back gear oil cup	SAE 10 or 10W spindle oil	Service cup when operating in back gear mode – service weekly

Fig. 27

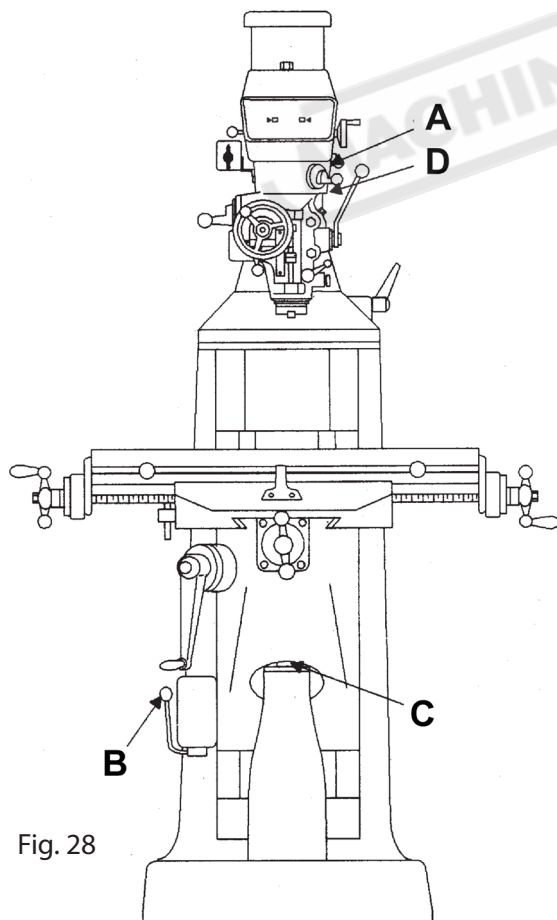

Fig. 28

#### Periodic Maintenance Requirements

During operation, periodically vacuum and brush chips and debris from the machine.

Periodically operate knee and table lead screws through full range of movement to evenly distribute lubricant (particularly when applied using the "one-shot" system).

Periodically apply light machine oil to work table and other exposed metal surfaces to prevent rust or corrosion.

BM-23A Periodically remove vent panels to check pulleys and belts for unusual wear or grooving.

BM-53VE, BM-63VE Operators should vary speed occasionally to prevent formation of grooves on the pulley surfaces.

When using the coolant pump, periodically clean the sump in the machine base to extend pump life and promote efficient cutting. Change coolant regularly at intervals recommended by the coolant supplier.

## GIB ADJUSTMENT

Gibs are tapered lengths of metal that are sandwiched between two moving surfaces. Gibs control the gap between these surfaces and how they slide past one another. Correctly adjusting the gibs is critical to producing good milling results.

Tight gibs make table movement more accurate but stiff. Loose gibs make moving the table sloppy but easier to do. The goal of gib adjustment is to remove unnecessary sloppiness without causing the ways to bind.

Gibs are adjusted with a screw on each end of the gib, that move the tapered gib back-and-forth to increase or decrease the friction pressure between the sliding surfaces. The process of properly adjusting the gibs requires trial-and-error and patience.

Refer to Fig. 29-31 to identify the locations of the table, saddle, and knee gibs, and one of the two adjustment screws for each.

**NOTE:** It will be necessary to remove small parts, such as way wipers and covers, to access the gib adjustment screws.

The following is the method used to adjust the gibs.

1. DISCONNECT MACHINE FROM POWER!
2. Make sure all table/knee locks are loose.
3. Loosen one gib adjustment screw, then `` tighten the other the same amount to move the gib.
4. Use ball handles/crank to move table/knee until you feel a slight drag in the path of movement. Repeat Steps 3–4 as necessary.

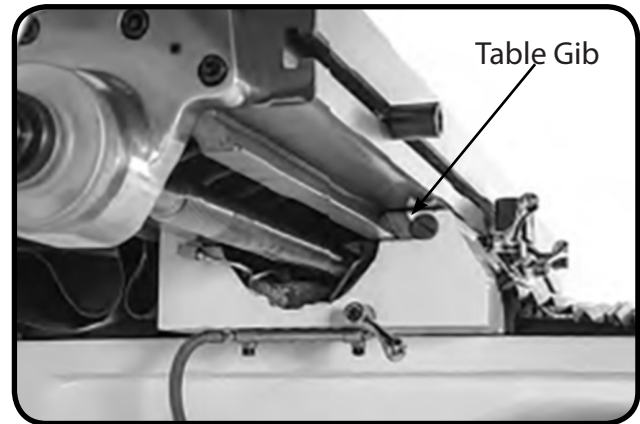

Fig. 29 Table Gib Adjustment

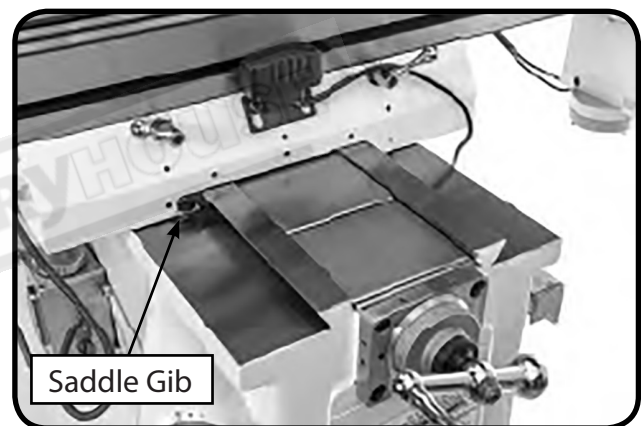

Fig. 30 Saddle Gib Adjustment

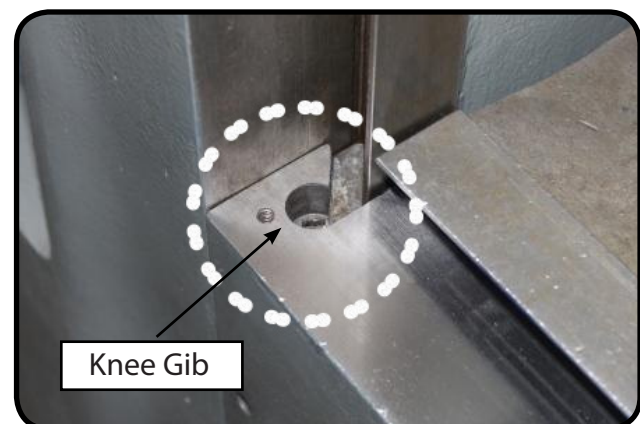

Fig. 31 Knee Gib Adjustment

## OPERATION MANUAL

### TROUBLESHOOTING

Read the troubleshooting section if a problem develops with your machine. If you need any assistance or additional help with a problem, call the Technical Support Department. For spare parts go to [www.machineryhouse.com.au/contactus](http://www.machineryhouse.com.au/contactus) and fill out the enquiry form attaching a copy of scanned parts list.

Symptom	Possible Cause	Possible Solution
Machine does not start or a breaker trips.	<ol style="list-style-type: none"> <li>1. Plug/receptacle at fault/wired wrong.</li> <li>2. Incorrect power supply voltage/circuit size.</li> <li>3. Power supply circuit breaker tripped or fuse blown.</li> <li>4. Motor wires connected incorrectly.</li> <li>5. Wiring open/has high resistance.</li> <li>6. Spindle rotation switch at fault.</li> <li>7. Start capacitor at fault .</li> <li>8. Centrifugal switch at fault .</li> <li>9. Motor at fault.</li> </ol>	<ol style="list-style-type: none"> <li>1. Test for good contacts; correct the wiring.</li> <li>2. Ensure correct power supply voltage/circuit size.</li> <li>3. Ensure circuit is sized correctly and free of shorts. Reset circuit breaker or replace fuse.</li> <li>4. Correct motor wiring connections.</li> <li>5. Check/fix broken, disconnected, or corroded wires.</li> <li>6. Replace switch.</li> <li>7. Test/replace.</li> <li>8. Adjust/replace centrifugal switch if available.</li> <li>9. Test/repair/replace.</li> </ol>
Machine stalls or is underpowered	<ol style="list-style-type: none"> <li>1. Machine undersized for task.</li> <li>2. Feed rate/cutting speed too fast.</li> <li>3. Wrong workpiece material.</li> <li>4. Belt(s) slipping.</li> <li>5. Oil/grease on belt(s).</li> <li>6. Motor wired incorrectly.</li> <li>7. Spindle rotation switch at fault.</li> <li>8. Gearbox at fault.</li> <li>9. Motor overheated.</li> <li>10. Pulley/sprocket slipping on shaft.</li> <li>11. Centrifugal switch at fault.</li> <li>12. Motor bearings at fault.</li> </ol>	<ol style="list-style-type: none"> <li>1. Use correct cutter/bit; reduce feed rate; reduce spindle RPM; use coolant if possible.</li> <li>2. Decrease feed rate/cutting speed.</li> <li>3. Use correct type/size of metal.</li> <li>4. Tension/replace belt(s); ensure pulleys are aligned.</li> <li>5. Clean belt(s).</li> <li>6. Wire motor correctly.</li> <li>7. Test/replace switch.</li> <li>8. Select appropriate gear ratio; replace broken or slipping gears.</li> <li>9. Clean motor, let cool, and reduce workload.</li> <li>10. Replace loose pulley/shaft.</li> <li>11. Adjust/replace centrifugal switch if available.</li> <li>12. Test/repair/replace.</li> </ol>
Machine has vibration or noisy operation.	<ol style="list-style-type: none"> <li>1. Workpiece loose.</li> <li>2. Belt(s) worn or loose.</li> <li>3. Motor or component loose.</li> <li>4. Chuck or cutter at fault.</li> <li>5. Belt(s) slapping headstock casting/guard.</li> <li>6. Motor fan rubbing on fan cover.</li> <li>7. Pulley loose.</li> <li>8. Machine incorrectly mounted.</li> <li>9. Motor bearings at fault.</li> <li>10. Centrifugal switch is at fault .</li> </ol>	<ol style="list-style-type: none"> <li>1. Use the correct holding fixture/reclamp workpiece.</li> <li>2. Inspect/replace belts with a new matched set.</li> <li>3. Inspect/replace damaged bolts/nuts, and retighten with thread locking fluid.</li> <li>4. Replace unbalanced chuck; replace/resharpen cutter; use correct feed rate.</li> <li>5. Replace/realign belts with a matched set.</li> <li>6. Fix/replace fan cover; replace loose/damaged fan.</li> <li>7. Re-align/replace shaft, pulley set screw, and key.</li> <li>8. Tighten mounting bolts; relocate/shim machine.</li> <li>9. Test by rotating shaft; rotational grinding/loose shaft requires bearing replacement.</li> <li>10. Replace</li> </ol>

## OPERATION MANUAL

### TROUBLESHOOTING

Symptom	Possible Cause	Possible Solution
Tool loose in spindle.	<ol style="list-style-type: none"> <li>1. Tool is not fully drawn up into spindle taper.</li> <li>2. Debris on tool or in spindle taper</li> <li>3. Taking too big of a cut.</li> </ol>	<ol style="list-style-type: none"> <li>1. Tighten drawbar.</li> <li>2. Clean tool and spindle taper.</li> <li>3. Lessen depth of cut and allow chips to clear.</li> </ol>
Breaking tools or cutters.	<ol style="list-style-type: none"> <li>1. Spindle speed/feed rate is too fast.</li> <li>2. Cutting tool is too small.</li> <li>3. Cutting tool getting too hot.</li> <li>4. Taking too big of a cut.</li> <li>5. Spindle extended too far down.</li> </ol>	<ol style="list-style-type: none"> <li>1. Set spindle speed correctly or use slower feed rate</li> <li>2. Use larger cutting tool and slower feed rate.</li> <li>3. Use coolant or oil for appropriate application.</li> <li>4. Lessen depth of cut and allow chips to clear.</li> <li>5. Fully retract spindle and raise table. This increases rigidity.</li> </ol>
Workpiece or tool vibrates or chatters during operation.	<ol style="list-style-type: none"> <li>1. Table locks not tight.</li> <li>2. Workpiece not secure.</li> <li>3. Spindle speed/feed rate is too fast.</li> <li>4. Spindle extended too far down</li> <li>5. Quill lock lever not tight.</li> <li>6. Gibs too loose in table.</li> </ol>	<ol style="list-style-type: none"> <li>1. Tighten table locks (Page 10).</li> <li>2. Properly clamp workpiece on table or in vise.</li> <li>3. Set spindle speed correctly or use slower feed rate (Page 15,16).</li> <li>4. Fully retract spindle and raise table This increases rigidity.</li> <li>5. Tighten quill lock lever (Page 8.9).</li> <li>6. Tighten gibs (Page 26).</li> </ol>
Table is hard to move.	<ol style="list-style-type: none"> <li>1. Table locks are tightened down.</li> <li>2. Chips have loaded up on ways.</li> <li>3. Ways are dry and need lubrication.</li> <li>4. Table limit stops are interfering.</li> <li>5. Gibs are too tight.</li> </ol>	<ol style="list-style-type: none"> <li>1. Fully release table locks (Page 10).</li> <li>2. Frequently clean away chips or debris.</li> <li>3. Lubricate ways (Page 25).</li> <li>4. Make sure that table limit stops are not in the way</li> <li>5. Adjust gibs (Page 26).</li> </ol>
Headstock is hard to raise.	<ol style="list-style-type: none"> <li>1. Headstock lock(s) or gib is at fault.</li> <li>2. Headstock leadscrew is binding.</li> <li>3. Gib is too tight.</li> </ol>	<ol style="list-style-type: none"> <li>1. Loosen/replace lock lever and adjust gib (</li> <li>2. Clean and relubricate headstock leadscrew and gears</li> <li>3. Adjust gib (Page 26).</li> </ol>
Bad surface finish	<ol style="list-style-type: none"> <li>1. Spindle speed/feed rate is too fast.</li> <li>2. Dull or incorrect cutting tool.</li> <li>3. Wrong rotation of cutting tool</li> <li>4. Workpiece not secure.</li> <li>5. Spindle extended too far down.</li> </ol>	<ol style="list-style-type: none"> <li>1. Set spindle speed correctly or use slower feed rate (Page 16).</li> <li>2. Sharpen cutting tool or select one that better suits the operation.</li> <li>3. Check for proper cutting tool rotation.</li> <li>4. Properly clamp workpiece on table or in vise.</li> <li>5. Fully retract spindle and raise table. This increases rigidity.</li> </ol>
Cutting results not square.	<ol style="list-style-type: none"> <li>1. Table and spindle are not at 90° to each other.</li> <li>2. Table travel is inconsistent</li> </ol>	<ol style="list-style-type: none"> <li>1. Square the spindle (Page 23).</li> <li>2. Adjust gibs (Page 26).</li> </ol>
Spindle overheats.	<ol style="list-style-type: none"> <li>1. Poor spindle bearing lubrication.</li> <li>2. Spindle bearings too tight.</li> <li>3. Mill operated at high speeds for extended period.</li> </ol>	<ol style="list-style-type: none"> <li>1. Replace spindle bearings.</li> <li>2. Properly adjust spindle bearing preload.</li> <li>3. Allow mill to cool.</li> </ol>
Lack of power at spindle.	<ol style="list-style-type: none"> <li>1. Belts are loose.</li> <li>2. Wrong voltage</li> </ol>	<ol style="list-style-type: none"> <li>1. Properly tension belts.</li> <li>2. Correct voltage.</li> </ol>

## OPERATION MANUAL

### TROUBLESHOOTING

Symptom	Possible Cause	Possible Solution
Spindle does not fully retract.	1. Poorly adjusted return spring. 2. Worn return spring.	1. Increase return spring tension. 2. Replace return spring
Spindle switch does not work.	1. Shorted/disconnected wiring.	1. Inspect wiring connections. Replace/repair as necessary.

### Power Feed

Powerfeed does not move table or is slipping.	1. Table locked. 2. Drive selector not engaged. 3. Sheared pin. 4. Gears not meshing or teeth missing. 5. Motor shaft and gear shaft not engaged	1. Unlock table locks. 2. Select speed, engage drive selector. 3. Replace pin. 4. Check gears and adjust/replace. 5. Replace clutch.
Operates at high speed only or is inconsistent.	1. Rapid micro switch is stuck. 2. V.R. does not work properly. 3. Wiring harness unplugged from circuit board	1. Lightly tap on it to lower it. 2. Test/repair/replace 3. Reconnect wiring harness.

### Digital Readout Unit (DRO)

DRO does not give reading.	1. DRO is not turned on/plugged in. 2. Shorted/disconnected wiring/plugs..	1. Press DRO ON/Power button/plug in. 2. Inspect circuit boards, sensors, plugs, and wiring connections. Replace/repair as necessary.
DRO reading is incorrect.	1. Initial reading is incorrect. 2. Sensor has gone bad. 3. Spacing between sensor & scale is incorrect.	1. Tare/zero/reset DRO at beginning point. 2. Test/replace sensor as necessary. 3. Adjust spacing between sensor and scale

### Lamp

Lamp will not light.	1. Power not turned on. 2. Bulb is burned out. 3. Short in wiring or wired incorrectly	1. Press switch/button on lamp or control panel. 2. Replace bulb. 3. Trace and test wiring. Fix any errors.
----------------------	--	---

## SPARE PARTS SECTION

The following section covers the spare parts diagrams and lists that were current at the time this manual was originally printed. Due to continuous improvements of the machine, changes may be made at any time without notification.

### HOW TO ORDER SPARE PARTS

1. Have your machines model number, serial number & date of manufacture on hand, these can be found on the specification plate mounted on the machine
2. A scanned copy of your parts list/diagram with required spare part/s identified
3. Go to [www.machineryhouse.com.au/contactus](http://www.machineryhouse.com.au/contactus) and fill out the enquiry form attaching a copy of scanned parts list.



OPERATION MANUAL

BM-23A BELT DRIVE HEAD

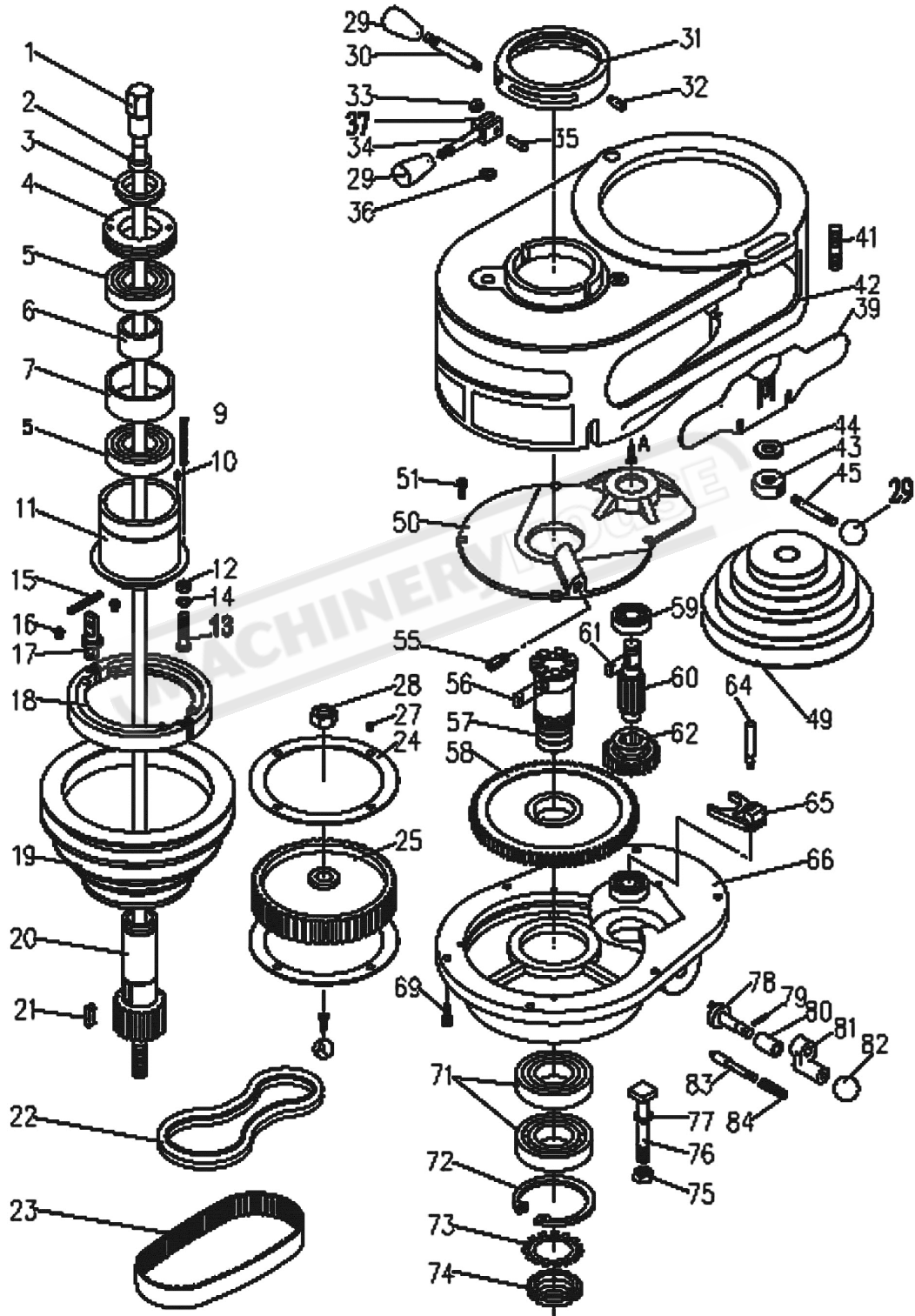



## OPERATION MANUAL

### Parts List for BM-23A Head Assembly

Index No.	Part No.	Description	Size	Q'ty
1	LA-072	Draw Bar	NT30 (W7/16-20UNF)	1
2	JTM4VS-A002B	Draw Bar Washer		1
3	LA-071	Upper Bearing Lock Nut		1
4	LA-070	Bearing Sleeve Lock Nut		1
5	BB-6207ZZ	Ball Bearing		1
6	LA-068	Upper Bearing Spacer (small)		1
7	LA-069	Upper Bearing Spacer (large)		1
9	LA-169	Compression Spring		1
10	TS-1520041	Set Screw	M3x10	2
11	LA-066	Spindle Pulley Bearing Sleeve		1
12	TS-0571021	Hex Jam Nut	5/16	1
13	TS-0720081	Lock Washer	5/16	1
14	LA-034	Brake Ring Screw		1
15	LA-036	Spring		2
16	BUTW1814	Screw W1/8x1/4		1
17	LA-037	Brake Lock Stud		1
18	LA-035	Brake Assembly		1
19	LA-065	Spindle Pulley		1
20	LA-064	Spindle Pulley Hub		1
21	JTM1-021	Key	8x7x24	1
22	VB-A33	V-belt	A-33	1
23	VB225L100	Timing Belt	2252x100	1
24	LA-027	Timing Belt Flange		1
25	LA-028	Timing Belt Pulley		1
27	JTM1-C27	Flat Head Screw	W1/8x1/4	1
28	TS-0571072	Hex Jam Nut	5/8-18UNF	1
29	LA-006	Plastic Ball	W3/8	2
30	LA-074	Spindle Clutch Lever		1
31	LA-073	Cam Ring		1
32	JTM1-032	Cam Ring Pin		1
33	JTM1-C33	E-Ring	E-5.5	1
34	LA-039	Brake Lock Handle		1
35	LA-038	Brake Lock Pin		1
36	TS-0680061	Washer	W1/2	1
37	JTM1-037	Spindle Speed Plate		1
39	JTM1-039	Belt Guard Assembly		2
41	LA-012	Motor Mount Studs		2
42	LA-015	Belt Housing		1
43	LA-007	Motor Lock Nut		1
44	LA-008	Washer		1
45	LA-009	Motor Lock Nut Handle		1
49	LA-011	Motor Pulley		1
50	LA-013	Gear Housing Cover		1
51	JTM1-C51	Hex Socket Cap Screw	M5x14	1
55	JTM1-055	Oil Cup		1
56	JTM1-C56	Key	8x7x15	1
57	LA-062	Spindle Gear Hub		1
58	LA-061	Spindle Bull Gear Assembly		1
59	BB-6203ZZ	Ball Bearing	6203ZZ	2
60	LA-026	Shaft		1
61	JTM1-061	Key	5x5x15	1
62	LA-025	Gear		1
64	LA-032	Dowel Pin		1
65	LA-031	Back Gear Shifter Fork		1
66	LA-014	Gear Housing		1



---

**OPERATION MANUAL**

---

**Parts List for BM-23A Head Assembly Cont.**

<b>Index No.</b>	<b>Part No.</b>	<b>Description</b>	<b>Size</b>	<b>Q'ty</b>
69	TS-1503041	Hex Socket Cap Screw	M6x16	1
71	BB-6208Z	Ball Bearing	6208Z	2
72	JTM1-C72	Snap Ring	R-80	1
73	JTM1-C73	Lock Washer		1
74	LA-059	Bearing Lock Nut		1
75	JTM1-C75	Hardened Nut	W7/16	1
76	LA-045	T-Bolt		1
77	JTM1-C77	Bolt Washer	W7/16	1
78	LA-001	Shift Crank		1
79	JTM-C79	Spring Pin	Ø3x20	1
80	LA-044	Back Gear Shift Bushing		1
81	LA-003	Shaft Crank Handle		1
82	LA-006	Plastic Ball		2
83	LA-004	Gearshift Plunger		1
84	LA-005	Compression Spring		1

MACHINERYHOUSE





# OPERATION MANUAL

## Spindle Assembly

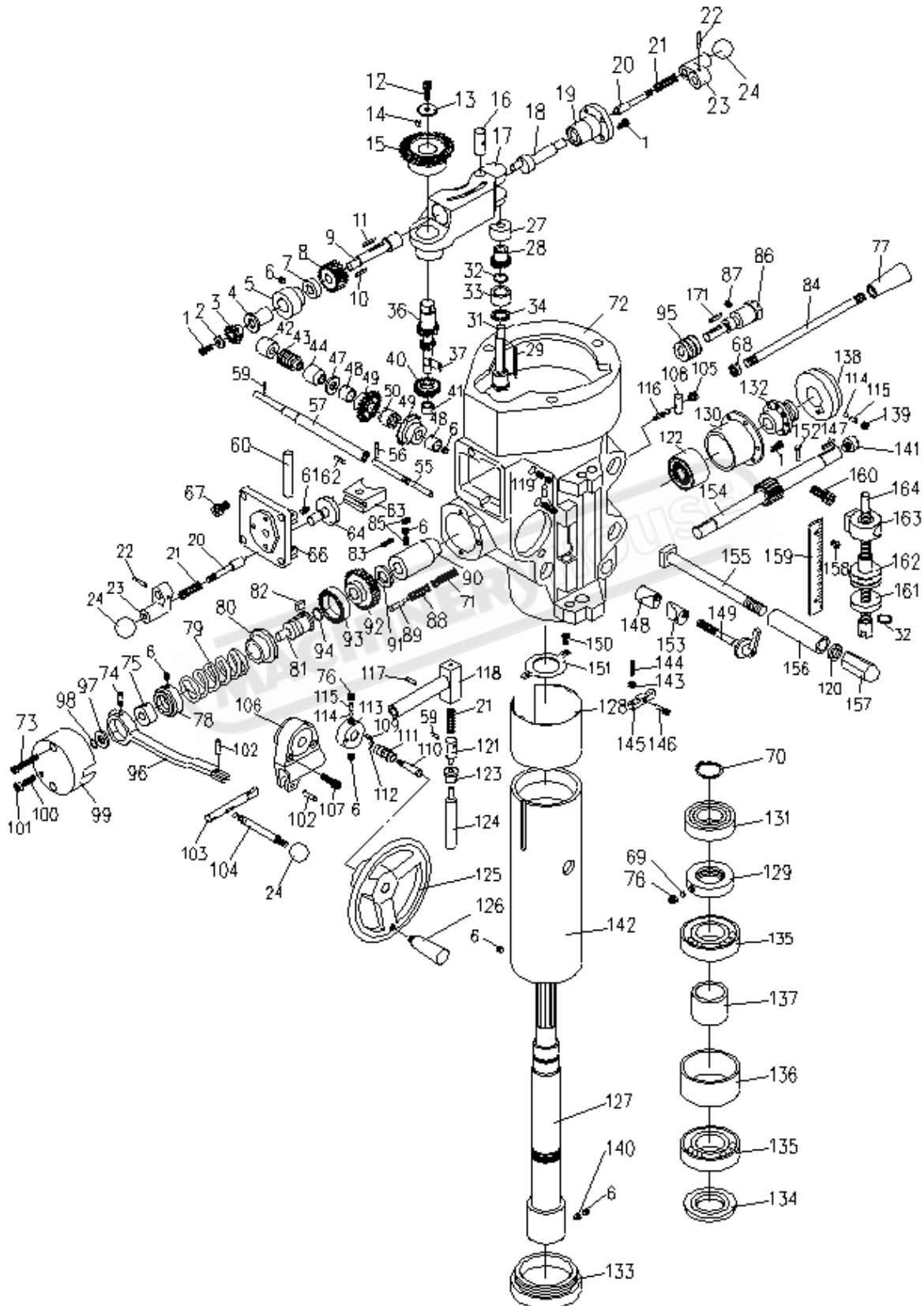



## OPERATION MANUAL

### List for Spindle Assembly

#### Index

No.	Part No.	Description	Size	Qt
1	TS-1533042	Screw	M5×10	6
2	HA-002	Bevel Pinion Washer		1
3	LA-166A	Feed Gear		1
4	LA-161	Shaft Sleeve		1
5	LA-162	Worm Cradle Bushing		1
6	TS-1523011	Set Screw	M6×6	9
7	LA-163	Worm Cradle Bushing		1
8	LA-164	Feed Drive Worm Gear		1
9	LA-165	Worm Gear Shaft		1
10	HA-010	Worm Shaft Key	3×3×8	6
11	LA-166A	Key	3×3×20	1
12	HA-012	Locknut	M6×16	1
13	LA-166A	Washer		1
14	HA-014	Cluster Gear Key	3×3×8.5	1
15	LA-154	Feed Reverse Bevel Gear		1
16	LA-167	Feed Engage Pin		1
17	LA-166	Worm Gear Cradle		1
18	LA-066	Cam Rod		1
19	LA-002	Shift Sleeve		1
20	LA-004	Plunger		2
21	LA-005	Spring		3
22	HA-022	Spring Pin	3×22	2
23	LA-033	Cam Rod		1
24	LA-006	Plastic Ball		6
27	LA-147	Upper Bushing		1
28	LA-144	Cluster Gear Assembly		1
29	HA-029	Cluster Gear Key	3×3×45	1
31	LA-143	Cluster Gear Shaft		1
32	HA-032	Snap Ring		2
33	LA-142	Bevel Gear Bushing		1
34	LA-141	Thrust Spacer		1
36	LA-156	Feed Drive Gear		1
37	LA-166A	Key		1
40	LA-157	Feed Drive Gear		1
41	HA-041	Needle Bearing		1
42	LA-168	Bushing		1
43	LA-139	Worm		1
44	LA-138	Feed Worm Shaft Bushing		1
47	LA-137	Bevel Gear Thrust Spacer		1
48	LA-134	Bushing		2
49	LA-135	Feed Worm Shaft Bushing		2
50	LA-136	Feed Reverse Clutch		1
55	LA-132	Reverse Clutch Rod		1
56	HA-056	Spring Pin	3×20	1
57	LA-133	Feed Worm Shaft		1
59	HA-059	Spring Pin	3×12	2
60	LA-150	Feed Worm Shaft		1
61	TS-1522031	Set Screw	M5×10	1
62	HA-062	Key	3×3×15	2
63	LA-149	Feed Gear Shaft Fork		1
64	LA-151	Cluster Gear Shift Crank		1
66	LA-148	Cluster Gear Cover		1
67	TS-1504011	Hex Socket Cap Screw	M8×10	4
68	TS-0561031	Hex Nut	3/8"	1
69	HB1291	Lock Washer		1
70	RINS30	Snap Ring		1

---

**OPERATION MANUAL**

---

**List for Spindle Assembly****Index**

<b>No.</b>	<b>Part No.</b>	<b>Description</b>	<b>Size</b>	<b>Qty</b>
71	HA-193	Spring	10x20	1
72	LA-016	Quill Housing		1
73	TS-1502081	Hex Socket Cap Screw	M5x35	2
74	LA-081	Clutch Ring Pin		2
75	LA-080	Clutch Ring		1
76	TS-1524011	Set Screw	M8x8	1
77	LB-017	Plastic Ball		1
78	LA-082	Overload Clutch Lockout		1
79	LA-083	Safety Clutch Spring		1
80	LA-084	Overload Clutch		1
81	LA-085	Overload Clutch Sleeve		1
82	LA-090	Key		1
83	TS-1532052	Pan Head Machine Screw	M4x16	3
84	LA-105	Handle		1
85	TS-1523031	Set Screw	M6x10	2
86	LA-019	Worm Shaft		1
87	LA-173	Set Screw		1
88	LA-169	Spring		1
89	LA-089	Spring Plunger		1
90	LA-123	Pinion Shaft Bushing		1
91	LA-122	Spacer		1
92	LA-087	Overload Clutch Worm Gear		1
93	LA-086	Overload Clutch Ring		1
94	LA-094	Snap Ring		1
95	LA-018	Worm Gear		1
96	LA-079	Trip Lever		1
97	LA-078	Washer		1
98	LA-098	Snap Ring		1
99	LA-076	Clutch Arm Cover		1
100	TS-1523051	Set Screw	M6x10	1
101	HA-101	Locknut		1
102	LA-077	Pin		1
103	LA-091	Cam Rod		1
104	LA-100	Trip Handle		1
105	LA-124	Screw		1
106	LA-092	Feed Trip Bracket		1
107	TS-1503051	Hex Socket Cap Screw	M6x20	2
108	LA-114	Plunger		1
109	HA-109	Key	3x3x10	1
110	LA-130	Feed Reverse Knob Stud		1
111	LA-131	Reverse Knob		1
112	HA-112	Snap Ring		1
113	LA-129	Handwheel Clutch		1
114	SB-3/16	Steel Ball	3/16"	2
115	HA-115	Spring		2
116	LA-113	Lever		1
117	HA-117	Spring Pin		1
118	LA-093	Cam Rod Sleeve Assembly		1
119	TS-1523011	Set Screw	M6x6	2
120	TS-0680061	Washer	1/2"	1
121	LA-095	Trip Plunger		1
122	LA-102	Clock Spring		1
	LA-102/3	Clock Spring Assembly		1
123	LA-121	Bushing		1
124	LA-097	Feed Trip Plunger		1



## OPERATION MANUAL

### Parts List for Spindle Assembly

#### Index

No.	Part No.	Description	Size	Qty
125	LA-126	Handwheel		1
126	LA-125	Handle		1
127	LA-050A	Spindle		1
128	LA-060	Quill Skirt		1
129	LA-048	Lock Nut		1
130	LA-103	Spring Cover		1
131	BB-6206ZZ	Ball Bearing	6206ZZ	1
132	LA-104	Hub Sleeve		1
133	LA-051	Nose Piece		1
134	LA-052	Spindle Shield		1
135	BB-7207C	Ball Bearing	7207C	2
136	LA-054	Bearing Spacer (large)		1
137	LA-053	Bearing Spacer (small)		1
138	LA-106	Hub	5/16"×1/4	1
139	TS-0270021	Set Screw		1
140	LA-172	Set Screw		1
141	LA-107	Pinion Shaft Hub		1
142	LA-058	Quill		1
143	TS-154021	Hex Nut	M4	1
144	TS-1521071	Set Screw	M4×20	1
145	LA-098	Feed Trip Lever		1
146	LA-099	Trip Lever Pin		1
147	HA-171	Key		2
148	LA-111	Quill Lock Sleeve		1
149	LA-109	Lock Handle		1
150	HA-150	Screw	M5×10	2
151	LA-057	Felt Washer		1
152	LA-101A	Pin		1
153	LA-110	Quill Lock Sleeve		1
154	LA-101	Quill Pinion Shaft		1
155	LA-043	T-Bolt Assembly		4
156	LA-046	Spacer		4
157	LA-040	Lock Nut		4
158	HA-158	Screw	M4×5	2
159	LA-118	Micrometer Scale		1
160	TS-0209032	Screw	3/8"-24UNF3/4	1
161	LA-115	Quill Micro-Stop Nut		1
162	LA-116	Micrometer Nut		1
163	LA-117	Quill Stop Knob		1
164	LA-112	Quill Micro-Screw		1



# OPERATION MANUAL

## BM-53VE Upper Head Parts List

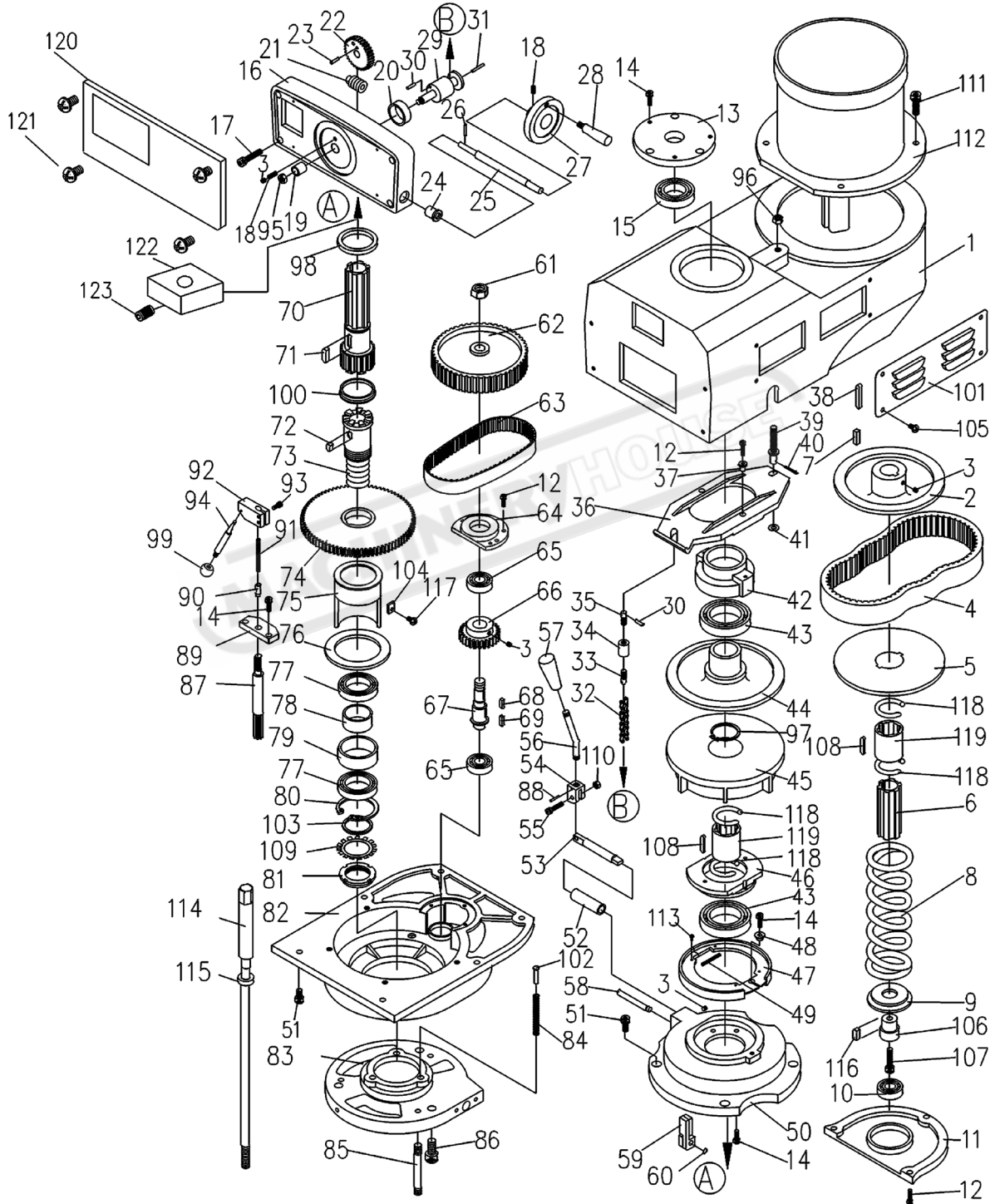



## OPERATION MANUAL

### BM-53VE Upper Head Parts List

#### Index

No.	Part No.	Description	Size	Qty.
1	VS-001	Upper Housing		1
2	VS-002	Motor Pulley		1
	VS-044A	Motor Pulley Bushing (not shown)		1
3	TS-1523011	Set Screw	M6x6	4
4	VS-004	Belt		1
5	VS-005	Motor Pulley Disk		1
6	VS-006	Motor Pulley Shaft		1
7	KEY7725	Key	7x7x25	1
8	VS-008	Motor Pulley Spring		1
9	VS-009	Spring Stop Washer		1
10	BB-6206ZZ	Ball Bearing	6206ZZ	1
11	VS-011A	Motor Pulley Cover		1
12	TS-1502051	Hex Socket Cap Screw	M5x20	8
13	VS-013	Cover		1
14	TS-1503041	Hex Socket Cap Screw	M6x16	10
15	BB-6007ZZ	Ball Bearing	6007ZZ	1
16	VS-016	Dial Cover		1
17	TS-1503071	Hex Socket Cap Screw	M6x30	4
18	TS-1523041	Set Screw	M6x16	2
19	VS-019	Bushing		1
20	VS-020	Bushing		1
21	VS-021	Worm		1
22	VS-022	Worm Gear		1
23	VS-023	Spring Pin	5x10	2
24	VS-024	Bushing		2
25	VS-025	Dial Control Shaft		1
26	VS-026	Spring Pin	3x12	1
27	VS-027	Dial Wheel		1
28	VS-028	Wheel Handle		1
29	VS-029	Shaft		1
30	VS-030	Spring Pin	4x16	2
31	VS-031	Spring Pin	3x25	1
32	VS-032	Speed Change Chain		1
33	VS-033	Adjustment Stud		1
34	VS-034	Sleeve Nut		1
35	VS-035	Adjustment Stud		1
36	VS-036	Tilter		1
37	VS-037	Bushing		2
38	KEY6645	Key	6x6x45	1
39	VS-039	Regulating Screw		1
40	VS-040	Spring Pin	3/32x3/4	1
41	VS-041	Washer		1
42	VS-042	Support		1
43	BB-6010VV	Ball Bearing		2
44	VS-044N	Driven Pulley Assembly		1
45	VS-045N	Steady Pulley		1
46	VS-046	Bearing Cover		1
47	VS-047	Brake Lining		1
48	VS-048	Lock Screw		1
49	VS-049	Brake Spring		2
50	VS-050	Lower Housing Cover		1
51	TS-1504031	Hex Socket Cap Screw	M8x20	4
52	VS-052	Brake Shaft Sleeve		1
53	VS-053	Brake Lock Shaft		1
54	VS-054	Brake Lock Block		1



## OPERATION MANUAL

### BM-53VE Upper Head Parts List Cont.

#### Index

No.	Part No.	Description	Size	Qty.
55	TS-1503061	Hex Socket Cap Screw	M6x25	1
56	VS-056	Brake Lock Handle		1
57	VS-057	Plastic Ball		2
58	VS-058	Brake Finger Pivot Stud		1
59	VS-059	Brake Stud		2
60	VS-060	Snap Ring	S-8	2
61	TS-0561072	Nut	5/8-18UNF	1
62	VS-062	Timing Belt Pulley		1
63	VB225L100	Belt		1
64	VS-064	Bearing Retainer		1
65	BB-6203ZZ	Ball Bearing	6203ZZ	2
66	VS-066	Bull Gear		1
67	VS-067	Counter Shaft		1
68	VS-068	Key	5X5X15	1
69	VS-069	Key	5x5x18	1
70	VS-070	Spindle Pulley Hub		1
71	VS-071	Key	8x7x24	1
72	VS-072	Key	8x7x12	1
73	VS-073	Spindle Gear Hub		1
74	VS-074	Spindle Gear Assembly		1
75	VS-075	Rack Cup		1
76	VS-076	Washer		1
77	BB-6908ZZ	Ball Bearing		2
78	VS-078	Bearing Washer		1
79	VS-079	Bearing Washer		1
80	VS-080	Snap Ring		1
81	VS-081	Nut		1
82	VS-082	Lower Housing		1
83	VS-083	Fixed Clutch Bracket		1
84	VS-084	Spring		3
85	VS-085	Stud		3
86	TS-1506021	Hex Socket Cap Screw	M12x25	3
87	VS-087	Gear Shift Pinion		1
88	VS-088	Pin		1
89	VS-089	Detent Plate		1
90	VS-090	Detent Washer		1
91	VS-091	Spring		1
92	VS-092	Pinion Block		1
93	TS-1503011	Hex Socket Cap Screw	M5x14	2
94	VS-094	Pinion Crank		1
95	VS-095	Cap Nut		1
96	TS-0561031	Hex Nut	3/8	1
97	VS-097	Snap Ring		1
98	VS-098	Wave Washer		1
99	VS-099	Plastic Ball		1
100	VS-100	Snap Ring		1
101	VS-101B	Cover		2
102	VS-102	Spring Shaft		3
103	VS-103	Washer		1
104	VS-104	Copper Washer		2
105	VS-105	Screw	1/4x3/8	8
106	VS-107	Shaft		1
107	TS-1504061	Hex Socket Cap Screw	M8x30	1
108	VS-120	Key	6x4x32	2
109	VS-109	Lock Washer		1
110	TS-1540041	Hex Nut	M6	1
111	TS-0209051	Hex Socket Cap Screw	3/8x1	4



---

**OPERATION MANUAL**

---

**BM-53VE Upper Head Parts List Cont.****Index**

<b>No.</b>	<b>Part No.</b>	<b>Description</b>	<b>Size</b>	<b>Qty.</b>
112	4VS-112	Motor		1
113	VS-113	Oval Head Screw	1/8x1/4	4
114	JTM1-001VS	Draw Bar	#30/NT40	1
115	JTM4VS-A002B	Draw Bar Washer		1
116	VS-116	Key		1
117	VS-117	Oval Head Screw	3/16x1/2	1
118	VS-007	Snap Ring		4
119	VS-005A	Plastic Sleeve		2
120	JTM4VS-120	Speed Chart		1
121	JTM4VS-121	Pan Head screw	M4	4
122	JTM4VS-122	Sensor Block		1
123	TS-1521041	Set Screw	M4X10	1

MACHINERYHOUSE





# OPERATION MANUAL

## Base Assembly

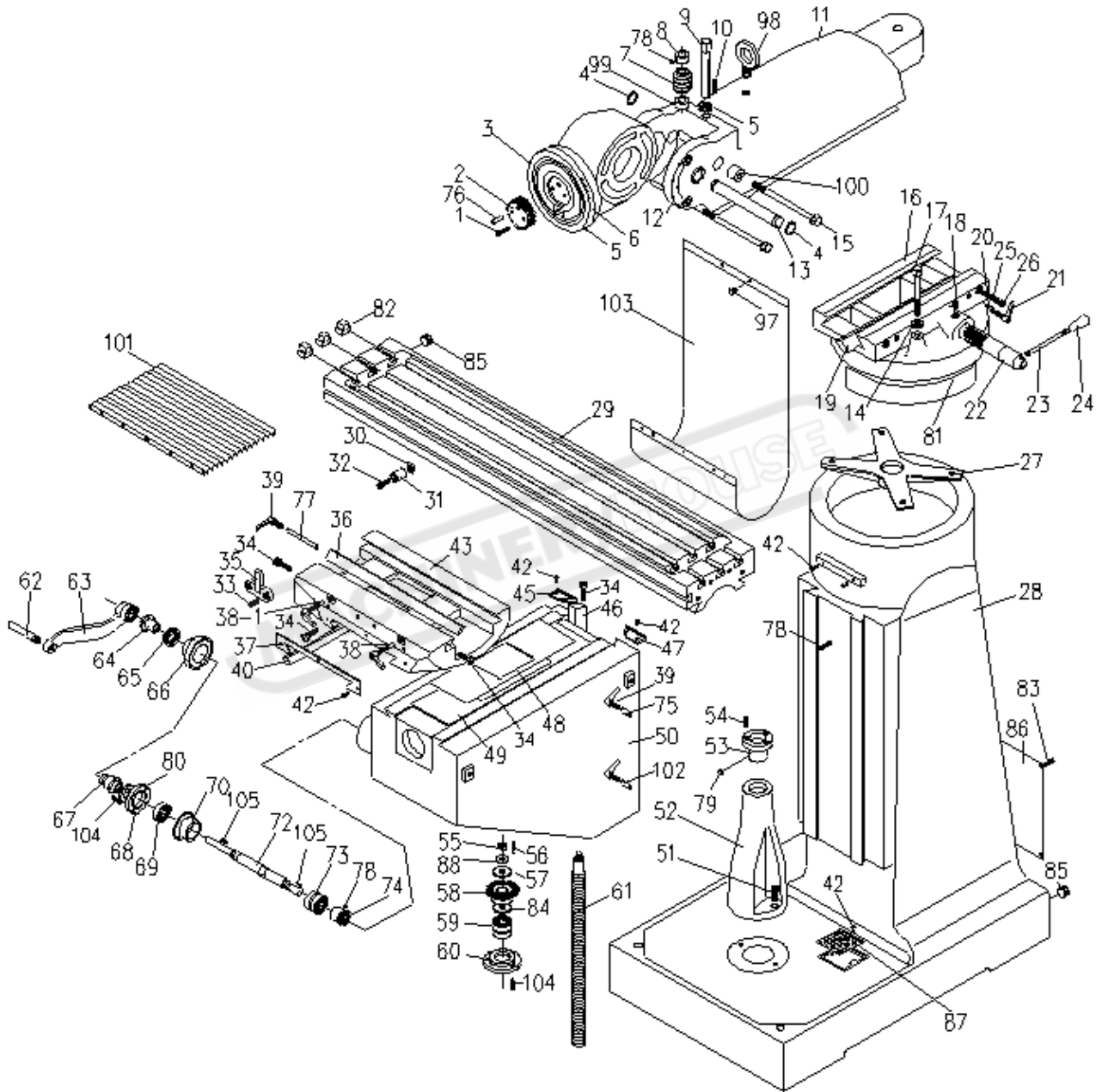



## OPERATION MANUAL

### Parts List for Base Assembly

#### Index

No.	Part No.	Description	Size	Qty
1	LB-001	Set Screw	M6×30	2
2	LB-023	Gear		1
3	LB-020	Ram Adapter		1
4	LB-004	Snap Ring		1
5	LB-005	Rivet	S-28	2
6	LB-027	Adapter Scale		5
7	LB-035	Worm		1
8	LB-036	Worm Thrust Washer		1
9	LB-034	Shaft		1
10	LB-100	Key	5×5×40	6
11	MB-026	Ram		1
12	LB-032	Angle Plate		1
13	LB-028	Adapter Pivot Stud		1
14	LB-031	Washer		4
15	LB-030	Adapter Locking Bolt	1/2"-12UNC	3
16	MB-009	Turret		1
	MB-00B	Turret Scale(not show)		1
17	LB-030	Lock Bolt	1/2"-12UNC	4
18	LB-041	Ram Pinion Screw	M8×1.25	1
19	LB-011	Ram/Turret Gib		1
20	LS-005E	Lock Plunger		2
21	LB-014	Ram Lock Bolt Handle	1/2"-12UNC	2
22	LB-015	Ram Pinion		1
23	LB-016	Handle	5/16"	1
24	LB-017	Black Plastic Ball		1
25	TS-0211131	Set Screw	3/8×2	2
26	TS-0561031	Hex Nut	3/8"	2
27	MB-008	Spider	1/2"-12UNC	1
28	MB-000	Column		1
29	JTM1-330A	Table		1
30	LT-027	Stop Nut	M8	2
31	LT-028	Table Stop		2
32	TS-1504071	Hex Socket Cap Screw	M8×35	2
33	TS-1504031	Hex Socket Cap Screw	M8×16	2
34	LK-002	Gib Adjusting Screw	5/16"	6
35	LS-003	Table Stop Bracket		1
36	LS-008	Saddle/Table Gib		1
37	LS-013	Felt Wiper		2
38	LS-005R	Table Lock Plunger-R	20mm	1
38-1	LS-005L	Table Lock Plunger-L	25mm	1
39	LS-011	Saddle Lock Handle	1/2"-12UNC	5
40	LS-001	Saddle/Knee Gib		1
41	LS-014	Wiper Plate		2
42	LS-042	Screw	3/16"×1/2"	16
43	MS-000	Saddle		1
44	LS-017A	Wiper Felt		2
45	LS-016A	Felt (left)		1
46	LK-001	Knee/Column Gib		1
47	LS-016A	Knee/Wiper Felt(right)		1
48	LK-007	Upper Chip Guard		1
49	LK-006	Upper Chip Guard		1
50	MK-000	Knee		1
51	TS-1505031	Hex Socket Cap Screw	M10×25	2
52	MK-012	Elevating Screw Housing		1
53	MK-014	Elevating Screw Nut		1
54	TS-1503041	Hex Socket Cap Screw	M6×16	8



## OPERATION MANUAL

### Parts List for Base Assembly Index

No.	Part No.	Description	Size	Qty
55	TS-0561052	Hex Nut	1/2"-20UNF	1
56	LK-058	Key	4x4x30	1
57	LK-022	Washer		1
58	MK-021	Bevel Gear	36t	1
59	BB-6306ZZ	Ball Bearing	6306ZZ	2
60	MK-019	Bearing Retainer Ring		1
61	MK-016	Elevating Screw		1
62	LK-037	Handle		1
63	LK-036	Elevating Crank	9t	1
64	MB-035	Clutch Insert	9t	1
65	MB-034	Dial Lock Nut		1
66	MB-033	Dial		1
67	MB-032	Dial Holder		1
68	MB-030	Bearing Retainer Ring		1
69	BB-6204ZZ	Ball Bearing	6204ZZ	1
70	MB-029	Bearing Cap		1
71	MB-075	Key	4x4x18	2
72	MK-028	Elevating Shaft		1
73	BB-6204ZZ	Ball Bearing	6204ZZ	2
74	MK-024	Bevel Pinion	18t	1
75	LK-003	Plunger	29mmL	1
76	LK-081	Spring Pin	8x30	1
77	LS-010	Saddle Lock Plunger	140mm	1
78	TS-1515001	Hex Socket Cap Screw	M8x12	1
79	JTM4VS-B79	Oil Block	1/4"	1
80	JTM4VS-B80	Spacer		1
81	JTM4VS-B81	Turret Scale		1
82	JTM4VS-B82	Rubber T-Nut		6
83	MB-090	Round Head Screw	1/4"x3/8"L	4
84	MK-038	Bushing		1
85	VM-I40	Oil Plug	3/8"PT	3
86	MB-004	Cover		1
87	MB-041	Strainer Screen		2
88	JTM4VS-B88	Lock Washer		1
97	JTM4VS-B97	Cross Round Head Screw	M6x12	7
98	RIBW34	Hoisting Ring	3/4"	1
99	LB-036	Worm Thrust Washer		1
100	LB-033	Thrust Washer		1
101	LS-018	Pleated Way Cover (front)		1
102	LK-003	Lock Plunger	32 mm L	1
103	LS-017C	Flat Way Cover (rear)		1
104	TS-1503051	Hex Socket Cap Screw	M6x20	6
103	LS-017C	Flat Way Cover (rear-not shown)		1
	JTM4VS-TB	Tool Box Kit Complete (not shown)		1
105	KEY3320	Key	3x3x20	1



# OPERATION MANUAL

## Lead Screw Assembly

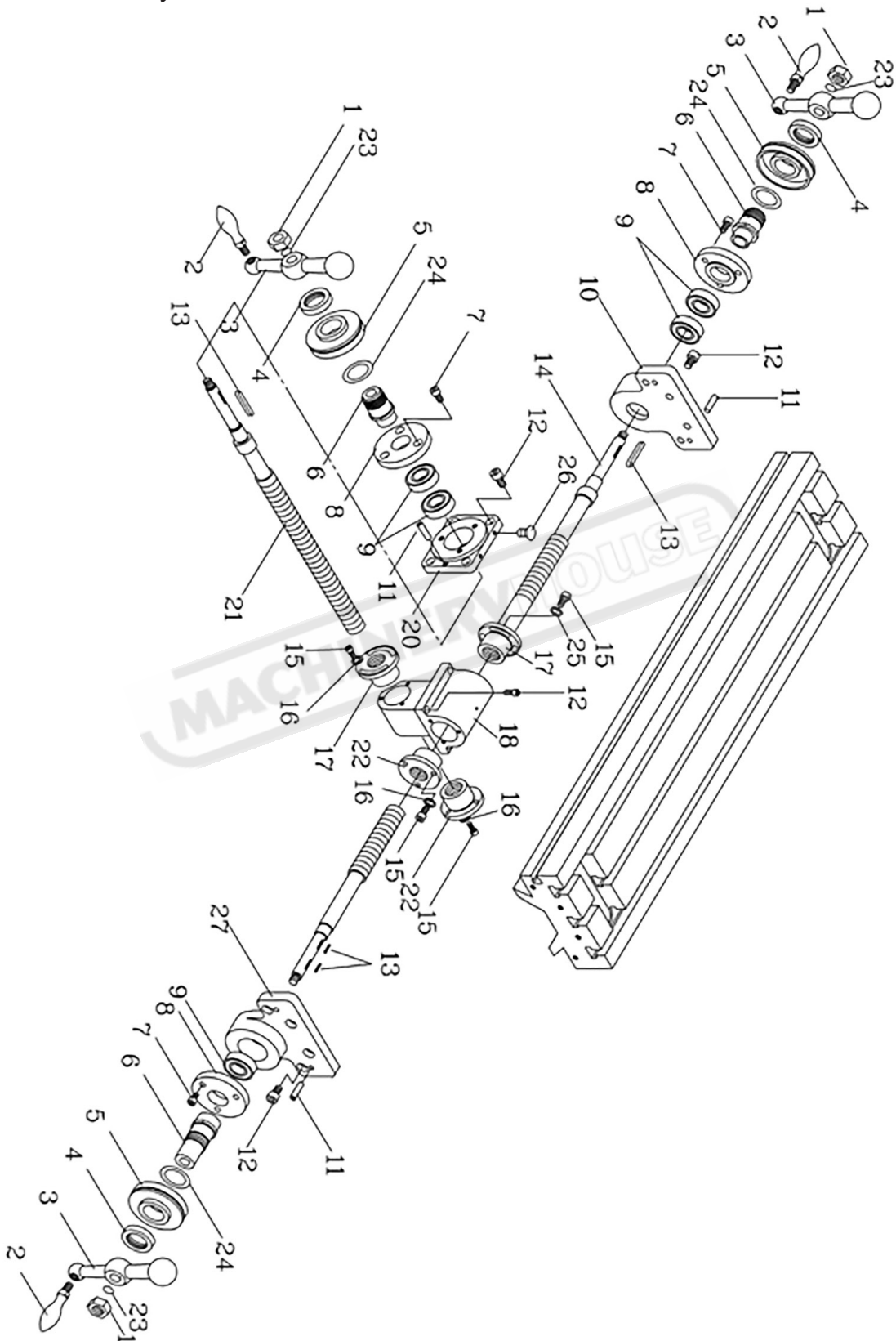

---

**HAFCO METALMASTER**

---

**OPERATION MANUAL**



---

**Lead Screw Parts List**

<b>Index No.</b>	<b>Part No.</b>	<b>Description</b>	<b>Size</b>	<b>Qty.</b>
1	D-1	Nut	1/2"-20NF	3
2	D-2	Handle		3
3	D-3	Ball Crank		3
4	D-4	Dial Lock Nut		3
5	D-5	Dial		3
6	D-6	Dial Holder		3
7	TS-1503031	Hex Socket Cap Screw	M6*12	9
8	D-90	Bearing Stop		3
9	BB-6204ZZ	Ball Bearing	6204ZZ	5
10	D-10	Bearing Bracket		2
11	D-11	Spring Pin	5*25	6
12	TS-1505031	Hex Socket Cap Screw		16
13	KEY3325	Key	3*3*25	3
14	D-14	Leadscrew		1
15	TS-1503061	Hex Socket Cap Screw		8
16	H-9	Washer		4
17	D-17	Feed Screw Nut		2
18	D-18	Feed Nut Bracket		1
20	D-20	Cross Bearing Bracket		1
21	D-21	Cross Feed Screw		1
22	D-22	Cross Feed Nut		2
23	D-23	Spring Washer	1/2"	3
24	D-24	Washer		3
25	D-25	Spring Washer		2
26	D-26	Screw		2
27	D-27	Bracket		1

## OPERATION MANUAL

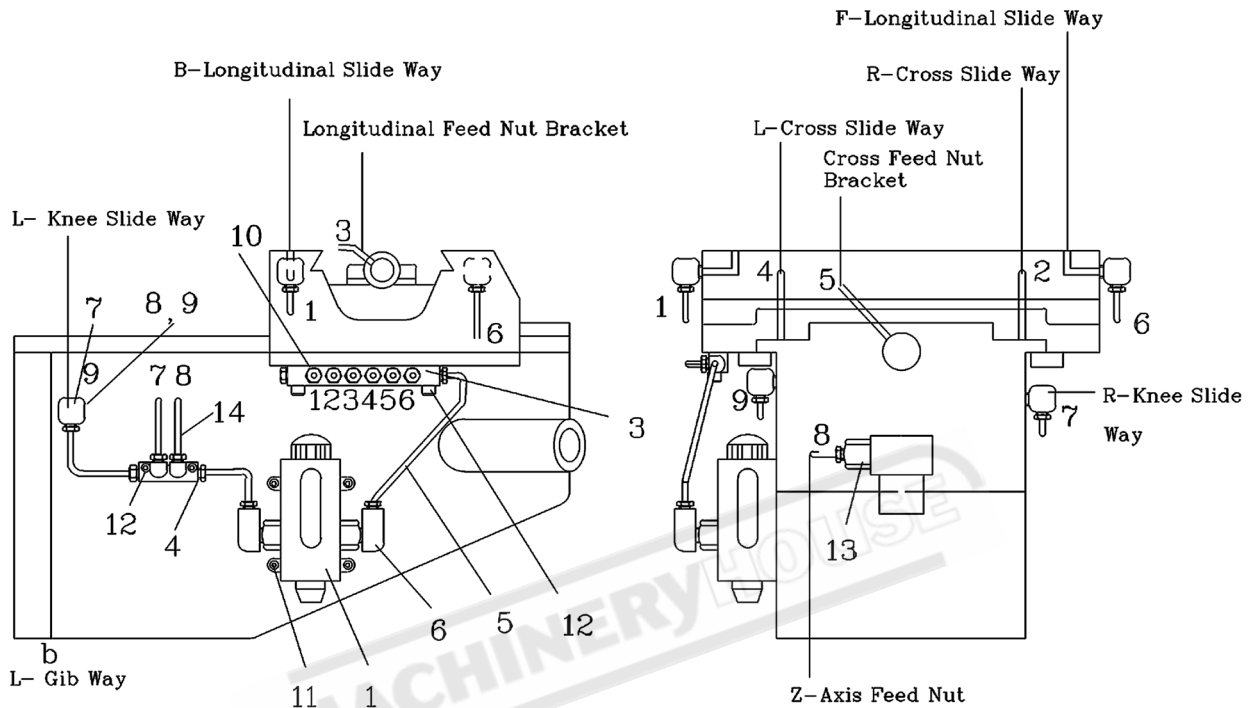
### ONE SHOT LUBRICATION DIAGRAM



#### Index

No.	Part No.	Description	Size	Qty
1	CLA-8	Hand Oiler		1
2	ALMP-04	Aluminum Pipe	13.5	1
3	A-8	Oil Regulating Distributor		1
4	A-4	Oil Regulating Distributor		1
5	A-5	Flexible Steel Tube	4x550	1
6	PH-4011	Elbow Joint		2
7	PA-401	Elbow Joint		6
8	PA-4	Thimble Nut		20
9	PB-4	Thimble		20
10	PG-004	Union		1
11	JTM4VS-BUTW1458	Screw	M6 x14	4
12	TS-1502061	Hex Socket Cap Screw	M5x25	4
13	PD-401	Straight Joint		1
14	A-14	Nylon Piece	4x700	1



# WARNING

## General Machinery Safety Instructions

---

Machinery House  
requires you to read this entire Manual before using this machine.

- 1. Read the entire Manual before starting machinery.** Machinery may cause serious injury if not correctly used.
- 2. Always use correct hearing protection when operating machinery.** Machinery noise may cause permanent hearing damage.
- 3. Machinery must never be used when tired, or under the influence of drugs or alcohol.** When running machinery you must be alert at all times.
- 4. Wear correct Clothing.** At all times remove all loose clothing, necklaces, rings, jewelry, etc. Long hair must be contained in a hair net. Non-slip protective footwear must be worn.
- 5. Always wear correct respirators around fumes or dust when operating machinery.** Machinery fumes & dust can cause serious respiratory illness. Dust extractors must be used where applicable.
- 6. Always wear correct safety glasses.** When machining you must use the correct eye protection to prevent injuring your eyes.
- 7. Keep work clean and make sure you have good lighting.** Cluttered and dark shadows may cause accidents.
- 8. Personnel must be properly trained or well supervised when operating machinery.** Make sure you have clear and safe understanding of the machine you are operating.
- 9. Keep children and visitors away.** Make sure children and visitors are at a safe distance for you work area.
- 10. Keep your workshop childproof.** Use padlocks, Turn off master power switches and remove start switch keys.
- 11. Never leave machine unattended.** Turn power off and wait till machine has come to a complete stop before leaving the machine unattended.
- 12. Make a safe working environment.** Do not use machine in a damp, wet area, or where flammable or noxious fumes may exist.
- 13. Disconnect main power before service machine.** Make sure power switch is in the off position before re-connecting.
- 14. Use correct amperage extension cords.** Undersized extension cords overheat and lose power. Replace extension cords if they become damaged.
- 15. Keep machine well maintained.** Keep blades sharp and clean for best and safest performance. Follow instructions when lubricating and changing accessories.
- 16. Keep machine well guarded.** Make sure guards on machine are in place and are all working correctly.
- 17. Do not overreach.** Keep proper footing and balance at all times.
- 18. Secure workpiece.** Use clamps or a vice to hold the workpiece where practical. Keeping the workpiece secure will free up your hand to operate the machine and will protect hand from injury.
- 19. Check machine over before operating.** Check machine for damaged parts, loose bolts, Keys and wrenches left on machine and any other conditions that may effect the machines operation. Repair and replace damaged parts.
- 20. Use recommended accessories.** Refer to instruction manual or ask correct service officer when using accessories. The use of improper accessories may cause the risk of injury.
- 21. Do not force machinery.** Work at the speed and capacity at which the machine or accessory was designed.
- 22. Use correct lifting practice.** Always use the correct lifting methods when using machinery. Incorrect lifting methods can cause serious injury.
- 23. Lock mobile bases.** Make sure any mobile bases are locked before using machine.
- 24. Allergic reactions.** Certain metal shavings and cutting fluids may cause an allergic reaction in people and animals, especially when cutting as the fumes can be inhaled. Make sure you know what type of metal and cutting fluid you will be exposed to and how to avoid contamination.
- 25. Call for help.** If at any time you experience difficulties, stop the machine and call you nearest branch service department for help.



## Milling Machine Safety Instructions

---

Machinery House  
requires you to read this entire Manual before using this machine.

- 1. Maintenance.** Make sure the mill is turned off and disconnect from the main power supply and make sure all moving parts have come to a complete stop before any inspection, adjustment or maintenance is carried out.
- 2. Mill Condition.** Mill must be maintained for a proper working condition. Never operate a mill that has damaged or worn parts. Scheduled routine maintenance should be performed on a scheduled basis.
- 3. Leaving a Mill Unattended.** Always turn the mill off and make sure all moving parts have come to a complete stop before leaving the mill. Do not leave mill running unattended for any reason.
- 4. Avoiding Entanglement.** Remove loose clothing, belts, or jewelry items. Never wear gloves while machine is in operation. Tie up long hair and use the correct hair nets to avoid any entanglement with the mill spindle or moving parts.
- 5. Chuck key safety.** Always remove your chuck key, draw bar wrench, and any service tools immediately after use. Chuck keys left in the chuck can cause serious injury.
- 6. Understand the machines controls.** Make sure you understand the use and operation of all controls.
- 7. Tooling selection & holding.** Always use the correct cutting tool for the job you are milling. Make sure it is sharp and held firmly in place.
- 8. Cutting Tool inspection.** Inspect Drill and end mills for sharpness, chips, or cracks before use. Replace any cutting tools immediately if dull, chipped or cracked. Handle new cutting tools with care. Cutting edges are very sharp and can cause lacerations.
- 9. Reversing the spindle.** Make sure the spindle has come to a complete stop before changing the direction of the spindle. Do not slow or stop the spindle by using your hand.
- 10. Stopping the spindle.** Do not slow or stop the spindle by using your hand.
- 11. Speed selection.** Select the appropriate speed for the type of work, material, and tool bit. Allow the mill to reach full speed before beginning a cut.
- 12. Clearing chips.** Always use a brush to clear chips. Never clear chips when the mill is running.
- 13. Power outage.** In the event of a power failure during use of the mill, turn off all switches to avoid possible sudden start up once power is restored.
- 14. Clean work area.** Keep the area around the mill clean from oil, tools and chips.
- 15. Tilting head.** Use an assistant to help support the head correctly. Make sure bolts that secure the head for tilting are not loosened to much as head can slip and cause serious injury. Please refer to Mill head Tilting Instructions for correct procedure.
- 16. Call for help.** If at any time you experience difficulties, stop the machine and call your nearest branch service department for help.



# PLANT SAFETY PROGRAM

## NEW MACHINERY HAZARD IDENTIFICATION, ASSESSMENT & CONTROL

### Milling Machine

Developed in Co-operation Between A.W.I.S.A and Australia Chamber of Manufactures  
This program is based upon the Safe Work Australia, Code of Practice - Managing Risks of Plant in the Workplace ( WHSA 2011 No10 )



Item No.	Hazard Identification	Hazard Assessment	Risk Control Strategies <small>(Recommended for Purchase / Buyer / User)</small>
A	ENTANGLEMENT	HIGH	Eliminate, avoid loose clothing / Long hair etc.
B	CRUSHING	LOW	Secure & support workpiece on mill table.
B	CRUSHING	HIGH	Mill head tilting adjustment - please refer to mill head tilting instruction sheet for correct procedure.
C	CUTTING, STABBING, PUNCTURING	MEDIUM	Incorrect adjustment may result in the head becoming detached and a crushing hazard Isolate power to machine prior to any checks or maintenance being carried out. Do not adjust or clean machine until the machine has fully stopped.
D	SHEARING	MEDIUM	Make sure all guards are secured shut when machine is on. Isolate power to machine prior to any checks or maintenance.
F	STRIKING	MEDIUM	Ensure tooling is secure in chuck. Wear safety glasses. Stand clear of moving parts on machine. Remove all loose objects around moving parts. Ensure correct spindle direction when milling.
H	ELECTRICAL	MEDIUM	All electrical enclosures should only be opened with a tool that is not to be kept with the machine. Machine should be installed & checked by a Licensed Electrician.
M	HIGH TEMPERATURE	LOW	Wear appropriate protective clothing to prevent hot swarf.
O	OTHER HAZARDS, NOISE.	LOW	Wear hearing protection as required.
Plant Safety Program to be read in conjunction with manufactures instructions			



[www.machineryhouse.com.au](http://www.machineryhouse.com.au)



[www.machineryhouse.co.nz](http://www.machineryhouse.co.nz)

Authorised and signed by:  
Safety officer:   
Manager: 

Revised Date: 12th March 2012